

PVC-U

Pipe and fittings

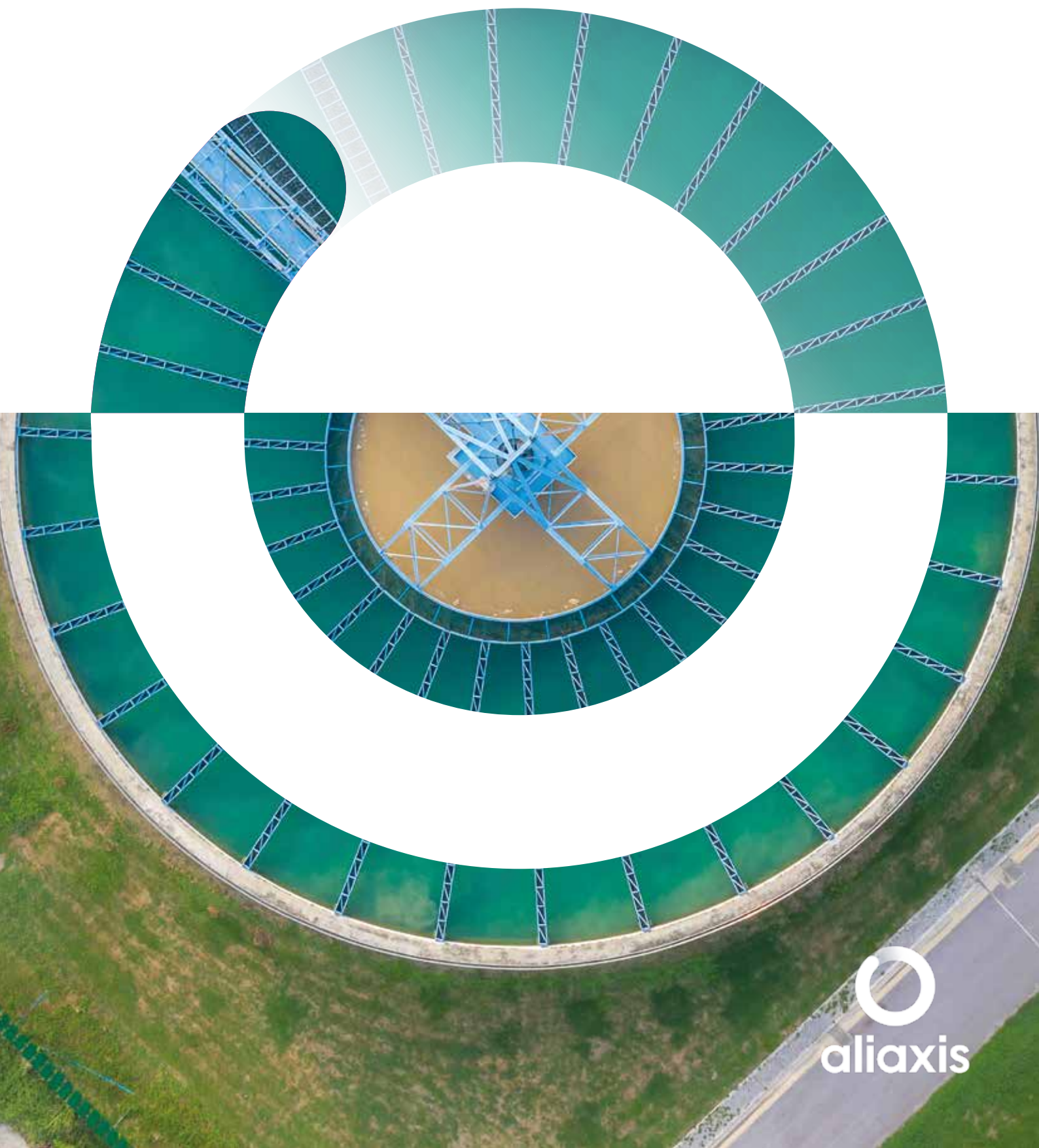

Contents

PVC-U

General characteristics	2
Reference standards	4
Approvals and quality marks	6
Solvent welding instructions	8
Installation instructions for threaded joints	13
Main properties	14

ISO-UNI pipe

PVC-U pressure pipe	18
---------------------	----

ISO-UNI fittings

Solvent weld fittings, metric series	26
--------------------------------------	----

ISO-BSP fittings

Adaptor fittings	62
------------------	----

BSP fittings

Threaded fittings	86
-------------------	----

BS fittings

Solvent weld and threaded fittings	106
------------------------------------	-----

Key abbreviations

128



PVC-U

General characteristics

Developed in 1930 in Germany, PVC-U (rigid polyvinyl chloride - unplasticized) is obtained through the polymerization of a vinyl chloride monomer. The presence of chlorine in the PVC-U molecule results in a high performance resin, in terms of thermal stability and chemical and mechanical resistance, up to temperatures of 60° C.

The different formulations obtained by adding suitable additives and stabilizers render the PVC-U the most versatile of all plastic materials, allowing it to be adapted to many applications involving fluids under pressure.

PVC-U represents one of the more economic solutions in the field of thermoplastic and metal materials for resolving problems in the transport of corrosive chemical fluids, and in the distribution and treatment of water in general.

The main reasons for this preference are the unique characteristics of the resin, which include:

- **Good chemical resistance:** PVC-U resins have excellent chemical resistance to most acids and alkalis, paraffin/aliphatic hydrocarbons and saline solutions. It is not recommended for the transport of polar organic compounds, including some types of chlorinated and aromatic solvents. PVC-U resins are also fully compatible with the transport of foodstuffs, demineralised water, potable water and unconditioned water, as provided for by current national and international standards.
- **Good thermal stability:** PVC-U resins have good thermal stability in the temperature range between 20°C and 50°C and are typically used in industrial and water supply applications, guaranteeing excellent mechanical strength, sufficient rigidity for the purpose, reduced thermal expansion coefficients and high factors of safety in service. PVC-U compounds are also resistant to combustion with a flash point of 399°C. The flame, in fact, only persists if the oxygen concentration is twice that of atmospheric or in the presence of a flame from an external source. Flash point: 399° C. Oxygen index: 45%. UL 94 class: V0.
Thanks to the reduced coefficient of thermal conductivity ($\lambda = 0,15 \text{ W/m } ^\circ\text{C}$ according to ASTM C177) the use of PVC-U resin for transporting hot fluids reduces heat loss and virtually eliminates condensation problems.
- **Good mechanical strength:** PVC-U resins are characterised by their low permeability to oxygen and reduced water absorption (0.1% at 23°C according to ASTM D 570). The thermal stability of the material leads to good impact resistance and the capacity to support service pressures of 4 - 6 - 10 - 16 bar at 20°C.
- **Resistance to ageing:** PVC-U resins have a high circumferential breaking strength (Minimum Required Strength MRS $\geq 25.0 \text{ MPa}$ at 20°C) and allow long installation lifetimes without showing any signs of significant physical-mechanical deterioration.

Density	
Test method	ISO 1183 - ASTM D792
Unit of measurement	g/cm ³
Value	1,38
Modulus of elasticity	
Test method	ISO 527
Unit of measurement	MPa = N/mm ²
Value	3200
IZOD notched impact strength at 23°C	
Test method	ASTM D256
Unit of measurement	J/m
Value	50
Ultimate elongation	
Test method	ISO 527
Unit of measurement	%
Value	50
Shore hardness	
Test method	ISO 868
Unit of measurement	Shore D
Value	80
Tensile strength	
Test method	ISO 527
Unit of measurement	MPa = N/mm ²
Value	50
VICAT softening point (B/50)	
Test method	ISO 306
Unit of measurement	°C
Value	76
Heat distortion temperature HDT (0.46 N/mm²)	
Test method	ASTM D648
Unit of measurement	°C
Value	86
Thermal conductivity at 23°C	
Test method	DIN 52612-1 - ASTM C177
Unit of measurement	W/(m °C)
Value	0,16
Coefficient of linear thermal expansion	
Test method	DIN 53752 - ASTM D696
Unit of measurement	m/(m °C)
Value	8 x 10 ⁻⁵
Limiting Oxygen Index	
Test method	ISO 4859-1 - ASTM D2863
Unit of measurement	%
Value	45

PVC-U

Reference standards

Production of the PVC-U lines is carried out according to the highest quality standards and in full compliance with the environmental restrictions set by the applicable laws in force and in accordance with **ISO 14001**.

All products are made in accordance with the quality guarantee system in compliance with **ISO 9001**.

- **ASTM D 1784 cl. 12454**
Rigid PVC-U and PVC-C compounds (for industrial applications).
- **ASTM D 1785**
Standard specification for pipes in PVC, Sch. 40-80-120
- **ASTM D 2464**
Standard Specification for Threaded Poly Vinyl Chloride (PVC) Plastic Pipe Fittings
- **ASTM D 2467**
Standard Specification for Poly Vinyl Chloride (PVC) Plastic Pipe Fittings, Schedule 80
- **BS 10**
Specification for flanges and bolts for pipes, valves and fittings
- **BS 3505**
Specification for PVC-U pressure pipes for cold water supplies
- **BS 4346-1**
Joints and fittings for use with solvent weld PVC pressure pipes
- **DIN 2501**
Flanges, dimensions
- **DIN 2999**
Whitworth thread for threaded pipes and fittings
- **DIN 8061**
PVC-U pipes: General quality requirements and testing
- **DIN 8062**
PVC-U pipes - dimensions
- **DIN 8063**
PVC-U pipe fittings - dimensions
- **DVS 2204 - DVS 2221**
Adhesive bonding of thermoplastic PVC-U pipes and fittings

- **EN 1092-1**

Flanges and their joints - Circular flanges for pipes, valves and accessories
- Part 1: PN designated steel flanges

- **EN ISO 1452**

PVC-U pipes and fittings for water supply systems

- **EN ISO 15493**

Plastic piping systems (Pipes, Fittings and Valves) in ABS, PVC-U, PVC-C
for industrial applications

- **ISO 7**

PVC-U fittings with pressure-tight threaded joints

- **ISO 161-1**

Dimensions of PVC-U pipes and fittings, metric series

- **ISO 228-1**

PVC-U pipe fittings with threaded joints

- **ISO 727**

PVC-U pipes and fittings Dimensions and tolerances, metric series

- **JIS K 6741**

PVC-U pipes

- **JIS B 0203**

Tapered pipe threads

- **JIS K 6743**

PVC-U pipe fittings for water supply systems

- **UNI 11242**

Solvent welding of PVC-U pipes, fittings and valves

Approvals and quality marks



- **ABS**

The FIP PVC-U system is recognised as suitable for conveying and treating sanitary and conditioning water onboard ships and other units classified by the American Bureau of Shipping (ABS)



- **ACS France (Attestation de conformité Sanitaire)**

Suitability of PVC-U for food and beverage applications



- **BSI (British Standards Institution UK)**

Suitability of PVC-U for food and beverage applications



- **Bureau Veritas (France)**

Suitability of PVC-U for conveying and treating sanitary and conditioning water in the maritime sector



- **CSTB**

PVC-U fittings and pipes to standard EN ISO 1452



- **IIP N. 122 Istituto Italiano dei Plastici (Italian Plastics Institute)**

PVC-U fittings and pipes to standard UNI EN ISO 1452



- **KIWA (Keurings Instituut Voor Waterleiding Artikelen Holland)**
PVC-U fittings to standard KIWA BRL K17301



- **UKR SEPRO**
FIP PVC-U fittings are certified in accordance with Ukrainian Health, Safety, Hygiene and Quality standards



- **WRAS (Water regulations advisory scheme - UK)**
Suitability of PVC-U for transporting potable water



- **RMRS**
FIP PVC-U system have been recognised as suitable for conveying, treating domestic and air conditioning waters on board ships and other units classified by the Russian Maritime Register of Shipping



- **DNV-GL**
FIP PVC-U system have been recognised as suitable for conveying, treating domestic and air conditioning waters on board ships and other units classified by DNV-GL



- **NIZP**
FIP PVC-U fittings have been recognised as suitable for conveying drinking water by the NIZP (National Institute of Public Health - Poland)

Solvent welding

Instructions

Solvent welding, or cement jointing, is the longitudinal joining system for connecting rigid PVC-U pipes and fittings.

The "cementing" is carried out using adhesives/cements obtained by dissolving PVC-U polymer in a solvent mixture. This solvent liquefies the walls of the pipe and/or fitting, allowing the constituent material to chemically combine and be subsequently welded. Chemical welding allows permanent joints to be achieved possessing chemical and mechanical strength characteristics identical to those of the pipes and fittings joined. The adhesives/solvent cements must be selected according to the type of thermoplastic resin to weld, in that the nature of the solvents vary, as does the weld material contained in them. It must be remembered, therefore, that all the solvent cements designed for joining thermoplastic pipes and fittings must be used to join pipes, fittings and valves of the same material.

Before starting any solvent welding operations, the efficiency and condition of the equipment used and the pieces to be assembled must be verified, in particular the uniformity, fluidity and expiry date of the solvent cement.

- 1)** Cut the pipe perpendicular to its axis to obtain a clean square section, preferably using a wheeled pipe cutter designed specifically for thermoplastic pipes (fig. 1).
- 2)** Chamfer the outer edges of the pipe in order to ensure that it enters the socket of the fitting at an angle of 15°. The chamfering operation must be carried out at all costs, otherwise the lack of chamfer can lead to the solvent being scraped off the surface of the fitting, thus compromising the effectiveness of the joint. The chamfering must be carried out using the appropriate chamfering tool (fig. 2).
- 3)** Measure the depth of the socket of the fitting to the internal shoulder and mark the corresponding distance on the end of the pipe (fig. 3 and 4).
- 4)** Using a clean paper towel or applicator soaked in Cleaner-Primer, remove any traces of dirt or grease from the outer surface of the pipe for the entire cementing length. Repeat the same operation on the internal surface of the socket of the fitting: leaving the surfaces softened (fig. 5).

Leave the surfaces to dry for a few minutes before applying the solvent cement. Remember that, in addition to cleaning the joint surfaces, the Cleaner-Primer also performs the important role of softening and preparing the surface to receive the solvent, an operation that enables a perfect joint to be obtained.

- 5)** Apply the solvent cement in a uniform manner longitudinally over both parts to be assembled (outer surface of the pipe and internal coupling surface of the fitting) using an applicator or suitably sized coarse brush.

For more detailed information, refer to the "Brush-applicator characteristics and dimensions" table.



Fig. 1



Fig. 2



Fig. 3



Fig. 4



Fig. 5

It is advisable to use an applicator/brush of dimension not less than half the diameter of the pipe. The solvent cement must be applied along the entire length of the joining surface of both the pipe and the fitting:

- for the entire joint length of the pipe previously marked on the outer surface (fig. 6)
- for the entire depth of the socket as far as the internal shoulder (fig.7)

6) Fully insert the pipe into the fitting immediately and without any rotation. Only after this operation will it be possible to slightly rotate both ends (max. 1/4 of a turn between pipe and fitting). This rotation movement will render the layer of applied solvent cement more uniform (fig. 8)

7) The pipe must be inserted in the fitting as soon and as quick as possible (after no more than 20-25 seconds is recommended). Depending on the external diameter of the pipe and, as a result, possible handling difficulties, the insertion of the pipe into the fitting must be carried out:

- manually by one person for external diameters < 90 mm.
- manually by two people for external diameters from d 90 to d < 160 mm.
- using mechanical pipe-pullers for external diameters > 160 mm.

8) Immediately after fully inserting the pipe in the fitting, apply pressure to the joined parts for a few seconds. Then use crepe paper or a clean cloth to remove any excess solvent cement from the outer surfaces, and from internal surfaces where possible (fig. 9).

9) Solvent cement drying: the joined parts must be left to stand in order to allow the solvent cement to set naturally without generating any unnecessary stress. The setting time depends on the amount of stress that the joint will be placed under.

In particular, the following minimum setting times must be respected according to the ambient temperature:

- before handling the joint:
 - from 5 to 10 minutes for ambient T. > 10°C
 - from 15 to 20 minutes for ambient T. < 10°C
- for repair joints on pipes of any size or pressure not subject to hydraulic testing:
 - 1 hour for each atm of applied pressure
- for joints in pipes and fittings of any diameter subject to pressure testing up to PN 16:
 - minimum 24 hours

The solvent cement setting times indicated are valid at ambient temperature (approx. 25°C.). For particular climatic conditions (humidity, temperature, etc...), we recommend you contact our technical services department and/or the solvent cement manufacturer for more information (fig. 10 and 11).



Fig. 6



Fig. 7



Fig.8



Fig.9

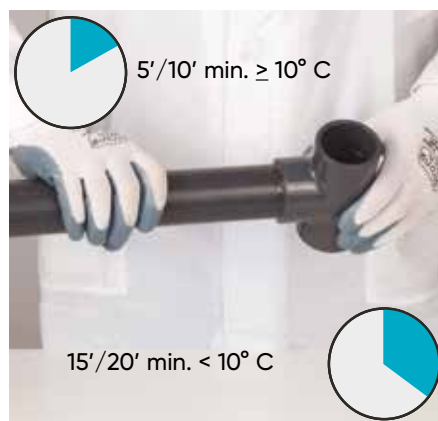

Fig.10

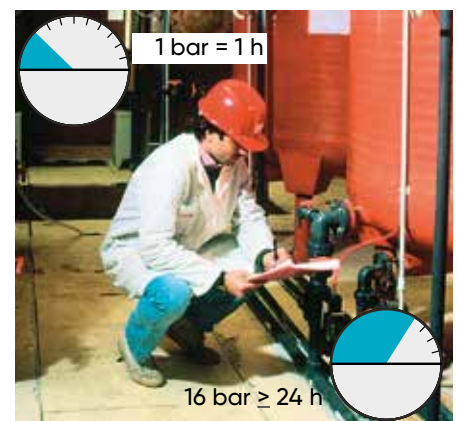
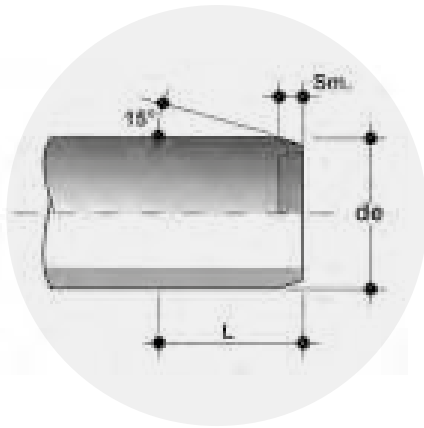

Fig.11



Socket depth, cement and chamfer length

External diameter		Cementing length L (mm)		Chamfer Sm (mm)
Metric series de (mm)	BS series (inches)	Metric series	BS series	
16	3/8"	14	14.5	
20	1/2"	16	16.5	1.5
25	3/4"	18,5	19.5	3
32	1"	22	22.5	3
40	1" 1/4	26	27	3
50	1" 1/2	31	30	3
63	2"	37,5	36	5
75	2" 1/2	43,5	43.5	5
90	3"	51	50.5	5
110	4"	61	63	5
125	-	68,5	-	5
140	5"	76	76	5
160	6"	86	90	5
180	-	96	-	5÷6
200	-	106	-	5÷6
225	8"	118,5	115.5	5÷6
250	-	131	-	5÷6
280	10"	146	142.5	5÷6
315	12"	163,5	168	5÷6

Characteristics and dimensions of brushes-applicators

External diameter		Type and dimensions of Brush or Applicator
de (mm)	(inch)	
16 - 25	3/8" - 3/4"	Round (8 - 10 mm)
32 - 63	1" - 2"	Round (20 - 25 mm)
75 - 160	2" 1/2 - 6"	Rectangular / round (45 - 50 mm)
>160	>6"	Rectangular / cylindrical (45 - 50 mm)
>160 - 315	>6" - 12"	Rectangular / cylindrical (60 - 65 mm)

Warnings

- In the case where the external diameter of the pipe and the internal diameter of the fitting are at opposite extremes of their tolerance values, the dry pipe cannot be inserted in the dry socket of the fitting. Insertion will only be possible after having applied the Cleaner and Solvent Cement to both parts to be joined.
- The solvent cement is manufactured from the same PVC resin used for the production of the pipes, fittings and valves. Unless otherwise specified, the solvent cement used on the surfaces to join must also be usable with the following tolerances:
 - maximum interference 0.2 mm,
 - maximum clearance 0.6 mm.
- When using the Cleaner and Solvent Cement, the following precautions should be adopted:
 - use gloves and safety glasses to protect hands and eyes.
 - use the Cleaner and Solvent Cement in a working environment with sufficient ventilation to avoid the formation of pockets of air containing concentrations of evaporated solvent, which can irritate the respiratory tract and eyes,
 - due to the volatile nature of the solvents in the cleaner and cement, the containers must be closed immediately after use,
 - Solvents in the gaseous phase tend to form flammable mixtures. Therefore, remove any ignition sources such as welding operations, accumulation of electrostatic charges, etc. from the work area, and do not smoke. In all cases, it is advisable to adhere strictly to the solvent cement manufacturer's instructions written on the packaging,
 - In order to prevent a deterioration in the performance of the cleaner and solvent cement, the joining operations should be carried out within an ambient temperature range of between + 5 and + 40° C.
- The amount of solvent cement used on the joints depends on a number of factors (environmental conditions, pipe size, cement viscosity, operator experience, etc.) which are often difficult to quantify. In this respect, Table "Rigid PVC-U pipes and fittings. Theoretical solvent cement consumption" reports the approximate quantities of cement normally used for joining various diameter pipes and fittings.
- After having completed all the joints and prior to putting the lines into service, make sure that the insides of the pipes and fittings are completely free of any solvent traces/ vapours. This will prevent contamination of the fluids conveyed.
- Table "Most common defects" reports the most common types of defect found if the correct solvent welding procedure is not followed.

Rigid PVC-U pipes and fittings theoretical solvent cement consumption

Pipe/Fitting diameter		Number of joints per kg of solvent cement
d (mm)	d (inches)	
16	3/8"	550
20	1/2"	500
25	3/4"	450
32	1"	400
40	1" 1/4	300
50	1" 1/2	200
63	2"	140
75	2" 1/2	90
90	3"	60
110	4"	40
125	-	30
140	5"	25
160	6"	15
180	-	12
200	-	10
225	8"	6
250	-	4
280	10"	2
315	12"	2

Most common defects

Solvent cement too fluid (incorrect diluent addition)	
Immediate effect	Cementing failure
Consequence	Joint separation or leaks from between the pipe and fitting
Excess solvent cement	
Immediate effect	Internal and external runs beyond the joint zone
Consequence	Weakening of the outer surface of the joint area and formation of bubbles with micro-cracks/sources of fracture in the base material
Excessively dense solvent cement due to evaporated solvent	
Immediate effect	Cementing failure
Consequence	Joint separation or leaks from between the pipe and fitting. Possible surface cracks triggering cracks in the base material
Insufficient and/or incorrect distribution of solvent cement	
Immediate effect	Cementing failure or local weakness
Consequence	Joint separation or leaks from between the pipe and fitting
Incorrect pipe insertion (incomplete, excessive, misaligned)	
Immediate effect	Imperfect joint
Consequence	Transmission of mechanical stresses from the pipe to the fitting and/or leaks from the joint
Impurities and/or humidity on the surfaces of the parts to join	
Immediate effect	Imperfect joint
Consequence	Joint separation or leaks (fluid seepage) from between the pipe and fitting

Installation instructions for threaded joints

To guarantee the hydraulic seal of the joint on fittings and valves with a threaded female end, we recommend you perform the following operations:

1. Start winding some PTFE sealing tape on the outside of the threaded male end, taking care not to obstruct the through-hole on the pipe, fitting or valve (fig. 1);
2. Complete the first winding layer by winding the tape clockwise until you reach the root of the thread. Remember to keep the tape taut throughout the entire process (fig. 2);
3. Press on the tips of the thread to make sure the tape adheres fully to the support clip;
4. Increase the thickness of the PTFE layer by continuing to apply the taut tape and winding it clockwise until you achieve the optimal level (fig. 3);
5. Connect the previously sealed male end to the female end and proceed manually by screwing the two elements;
6. Make sure the layer of PTFE is not removed during screwing, as this would compromise the hydraulic seal of the joint;
7. Complete screwing the two ends exploiting the entire length of the thread with the aid of a strap wrench or similar tool;
8. Avoid tightening the elements too much, as this could damage the threads or cause stress to the elements themselves.

Recommendations

For correct installation, we recommend you only use sealing tape in non-sintered PTFE. Under all circumstances avoid using materials such as hemp, lint or paints usually implemented for the hydraulic seal on metal threads.

Warnings

Avoid using threaded joints in the following cases:

- highly critical applications, such as for conveying chemically aggressive or toxic fluids,
- in the presence of medium or high pressures. In this case, we recommend the use of solvent welding joints, hot welding joints or flanged joints,
- systems subject to mechanical and/or thermal stresses such as water hammers, strong variations in temperature, bends, misalignments and cross tensions which could cause the threaded joint to break prematurely,
- coupling of elements with excessive distance from one another.



Fig. 1











Fig. 2



Fig. 3

Main properties

Properties of PVC-U		Benefits
Thermal resistance		<ul style="list-style-type: none"> • Service range 0–60 °C (see pressure/temperature regression curves)
Low surface roughness		<ul style="list-style-type: none"> • High flow coefficients (extremely smooth internal walls) • Pressure drop constant over time • Low risk of stoppages due to scaling • Reduced transfer of material to the transported fluid
Chemical resistance		<ul style="list-style-type: none"> • Good chemical resistance for conveying acids and alkalis, paraffin/aliphatic hydrocarbons and saline solutions.
Abrasion resistance		<ul style="list-style-type: none"> • Extremely low operating costs due to its long service life
Insulating		<ul style="list-style-type: none"> • Non-conductive (immune to galvanic corrosion) • No condensation problems • Minimum heat loss
Linear thermal expansion coefficients		<ul style="list-style-type: none"> • Reduced need for supports and expansion joints, resulting in considerable advantages in terms of plant design
Easy to join (solvent weld sockets)		<ul style="list-style-type: none"> • Reduced installation costs thanks to the “solvent weld” joint effected using a suitable solvent cement
Fire behaviour		<ul style="list-style-type: none"> • Good resistance to combustion also due to the presence of self-extinguishing chlorine
Good mechanical resistance		<ul style="list-style-type: none"> • PVC-U satisfies the need to provide adequate mechanical strength and complies with the requirements of industrial plant design



PIPE ISO-UNI

PVC-U

PRESSURE PIPE



PIPE ISO-UNI

Pipes under pressure with cold chemical weld jointing systems (solvent welding) using suitable solvent cement WELD-ON and primer-cleaner.

PRESSURE PIPE

Technical specifications	
Size range	d 16 ÷ d 315 (mm)
Nominal pressure	PN16 with water at 20° C PN10 with water at 20° C
Temperature range	0 °C ÷ 60 °C
Coupling standards	Solvent welding: EN ISO 15493, EN ISO 1452, DIN 8061/62
Reference standards	Construction criteria: EN ISO 15493, EN ISO 1452, DIN 8061/62 Test methods and requirements: EN ISO 15493, EN ISO 1452, DIN 8061/62 Installation criteria: DVS 2204, DVS 2221, UNI 11242 EN ISO 1452, DIN 8061/62
Material	PVC-U dark grey RAL 7011

TECHNICAL DATA

REGRESSION CURVE FOR PVC-U PIPE

Regression coefficients according to EN ISO 1452 and EN ISO 15493 for MRS (minimum required strength) values = 25 N/mm² (MPa) (classification PVC-U 250).

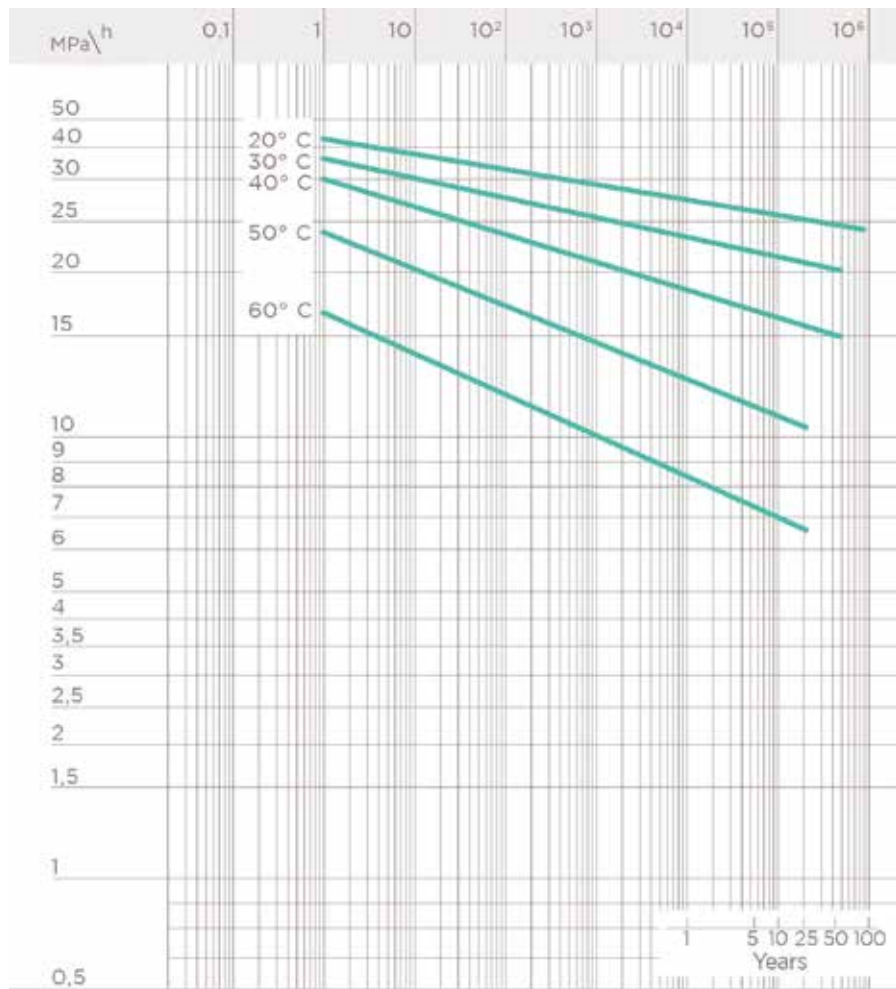

PRESSURE VARIATION ACCORDING TO TEMPERATURE

For water and non-hazardous fluids for which the material is classified as CHEMICALLY RESISTANT (life expectancy 25 years). In other cases, a reduction of the nominal pressure PN is required.



The information in this leaflet is provided in good faith. No liability will be accepted concerning technical data that is not directly covered by recognised international standards. FIP reserves the right to carry out any modification. Products must be installed and maintained by qualified personnel.

DIMENSIONS

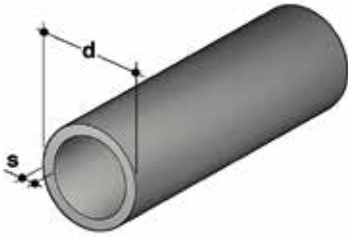

PRESSURE PIPE

PVC-U pressure pipe according to standard EN ISO 1452, dark gray RAL 7011, standard length 5m

d	S mm	kg/m	PN 16 *SDR 11 - SDR 13,6 - SDR 17 Code
16	1,5	0,109	PIPEV11016
20	1,5	0,140	PIPEV13020
25	1,9	0,216	PIPEV13025
32	2,4	0,351	PIPEV13032
40	3,0	0,539	PIPEV13040
50	3,7	0,831	PIPEV13050
63	4,7	1,323	PIPEV13063
75	5,6	1,877	PIPEV13075
90	6,7	2,681	PIPEV13090
110	6,6	3,289	PIPEV17110
125	7,4	4,194	PIPEV17125
140	8,3	5,265	PIPEV17140
160	9,5	6,872	PIPEV17160

*SDR 11: PN 20

d	S mm	kg/m	PN 10 SDR 21 - SDR 26 Code
32	1,6	0,246	PIPEV21032
40	1,9	0,360	PIPEV21040
50	2,4	0,567	PIPEV21050
63	3,0	0,878	PIPEV21063
75	3,6	1,258	PIPEV21075
90	4,3	1,798	PIPEV21090
110	4,2	2,175	PIPEV26110
125	4,8	2,800	PIPEV26125
140	5,4	3,533	PIPEV26140
160	6,2	4,632	PIPEV26160
180	6,9	5,774	PIPEV26180
200	7,7	7,160	PIPEV26200
225	8,6	8,996	PIPEV26225
250	9,6	11,167	PIPEV26250
280	10,7	13,961	PIPEV26280
315	12,1	17,817	PIPEV26315

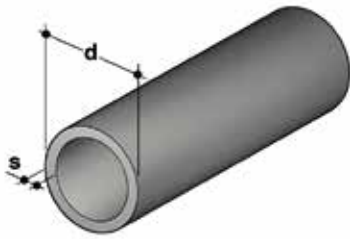

PRESSURE PIPE

PVC-U pressure pipe according to standards EN ISO 15493 and DIN 8061/8062, dark gray RAL 7011, standard length 5m

d	S mm	kg/m	PN 16 *SDR 11 - SDR 13,6 Code
16	1,5	0,109	PIPEV11016
20	1,5	0,140	PIPEV13020
25	1,9	0,216	PIPEV13025
32	2,4	0,351	PIPEV13032
40	3,0	0,539	PIPEV13040
50	3,7	0,831	PIPEV13050
63	4,7	1,323	PIPEV13063
75	5,6	1,877	PIPEV13075
90	6,7	2,681	PIPEV13090
110	8,1	3,940	PIPEV13110
125	9,2	5,070	PIPEV13125
140	10,3	6,563	PIPEV13140
160	11,8	8,563	PIPEV13160

*SDR 11: PN 20

d	S mm	kg/m	PN10 SDR 21 Code
32	1,6	0,246	PIPEV21032
40	1,9	0,360	PIPEV21040
50	2,4	0,567	PIPEV21050
63	3	0,878	PIPEV21063
75	3,6	1,258	PIPEV21075
90	4,3	1,798	PIPEV21090
110	5,3	2,670	PIPEV21110
125	6	3,410	PIPEV21125
140	6,7	4,412	PIPEV21140
160	7,7	5,780	PIPEV21160
180	8,6	7,462	PIPEV21180
200	9,6	8,990	PIPEV21200
225	10,8	11,356	PIPEV21225
250	11,9	13,892	PIPEV21250
280	13,4	17,529	PIPEV21280
315	15	22,020	PIPEV21315

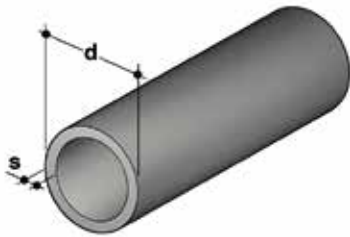

PRESSURE PIPE

PVC-U pressure pipe according to standards NF and CSTB NF055, dark gray RAL 7011, standard length 5m

d	S mm	kg/m	PN 16 SDR 13,6 - SDR 15 - SDR 17 Code
32	2,4	0,351	PIPEV13032
40	3,0	0,539	PIPEV13040
50	3,7	0,831	PIPEV13050
63	4,7	1,323	PIPEV13063
75	5,6	1,877	PIPEV13075
90	6,7	2,681	PIPEV13090
110	8,1	3,940	PIPEV13110
125	9,2	5,070	PIPEV13125
140	9,3	5,860	PIPEV15140
160	9,5	6,872	PIPEV17160

d	S mm	kg/m	PN 10 SDR 21 - SDR 23 - SDR 26 Code
63	3,0	0,878	PIPEV21063
75	3,6	1,258	PIPEV21075
90	4,3	1,798	PIPEV21090
110	5,3	2,670	PIPEV21110
125	6,0	3,410	PIPEV21125
140	6,1	3,940	PIPEV23140
160	6,2	4,632	PIPEV26160
180	6,9	5,774	PIPEV26180
200	7,7	7,160	PIPEV26200
225	8,6	8,996	PIPEV26225
250	9,6	11,167	PIPEV26250
315	12,1	17,817	PIPEV26315



ISO-UNI FITTINGS

PVC-U

Solvent weld fittings, metric series



ISO-UNI FITTINGS

Series of fittings designed for conveying fluids under pressure with a cold chemical weld jointing system (solvent welding) using a suitable solvent cement and cleaner-primer.

SOLVENT WELD FITTINGS, METRIC SERIES

Technical specifications	
Size range	d 12 ÷ d 500 (mm)
Nominal pressure	PN 16 with water at 20 °C
Temperature range	0 °C ÷ 60 °C
Coupling standards	Solvent welding: ISO 727, EN ISO 15493, DIN 8063, EN ISO 1452, ASTM D 2467, JIS K 6743, BS 4346-1. Can be coupled to pipes according to ISO 161-1, EN ISO 1452, EN ISO 15493, DIN 8062, ASTM D1785, JIS K6741, BS 3505-3506 Flanging system: DIN 2501, EN 1092-1
Reference standards	Construction criteria: EN ISO 1452, EN 1092-1 Test methods and requirements: EN ISO 1452, EN ISO 15493 Installation criteria: DVS 2204, DVS 2221, UNI 11242
Fitting material	PVC-U Grey RAL 7011
Seal material	EPDM, FKM

TECHNICAL DATA

PRESSURE VARIATION ACCORDING TO TEMPERATURE

For water and non-hazardous fluids for which the material is classified as CHEMICALLY RESISTANT (life expectancy 25 years). In other cases, a reduction of the nominal pressure PN is required.

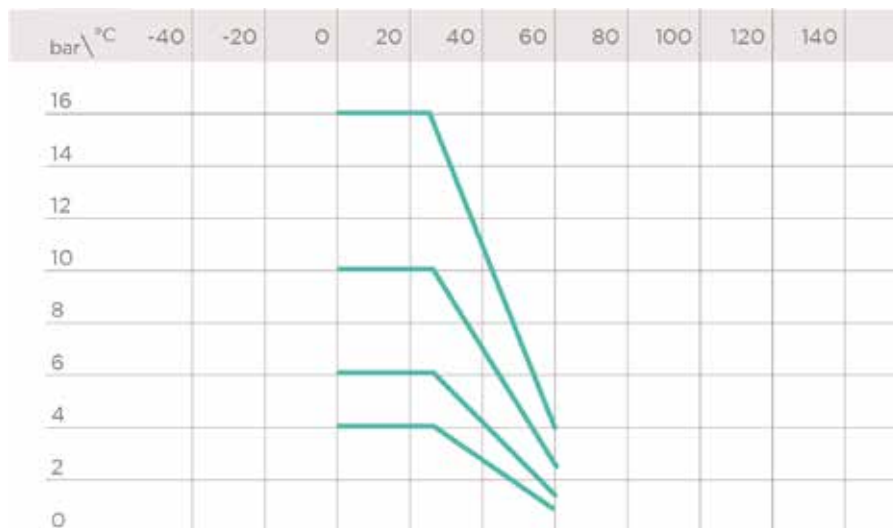

REGRESSION CURVE FOR PVC-U FITTINGS

Regression coefficients according to EN ISO 1452 and EN ISO 15493 for MRS (minimum required strength) values = 25 N/mm² (MPa) (classification PVC-U 250).

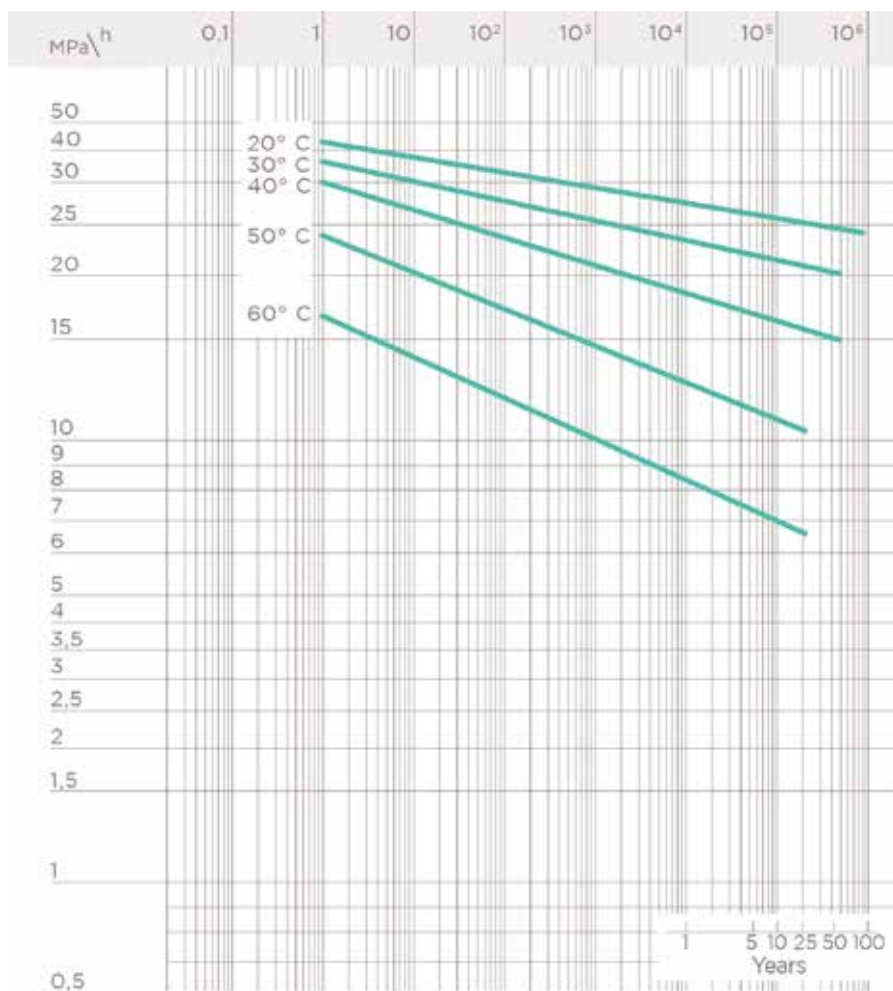

SAFETY FACTORS

The table reports the safety factors for each pressure class as a function of time.

Nominal pressure PN must be understood as being the standard pressure used for calculating and selecting the required fittings. In order to be able to comply with the safety factors, the maximum continuous working pressure at 20° C when conveying water must be the same as the nominal pressure values. Unless otherwise specified, the nominal pressures are as follows:

- solvent weld fittings from d 12 to d 225 PN 16 from d 250 to d 315 PN 10
- adaptor fittings from d 16 to d 110 PN 16
- threaded fittings from R 3/8" to R 4" up to PN 16.

Pe (bar)	1h	1000h	50 years	T
10	6,72	5,12	4	
16	4,2	3,2	2,5	

DIMENSIONS

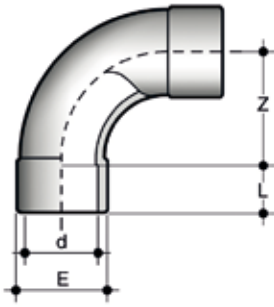

SIV

90° long radius bend (R=2d) with solvent weld sockets

	d	PN	E	L	Z	g	Code
IH	20	16	27	16	40,5	35	SIV020
IH	25	16	33	19	50	55	SIV025
IH	32	16	41	22	65,5	100	SIV032
IH	40	16	50	26	80,5	175	SIV040
IH	50	16	61	31	100,5	280	SIV050
IH	63	16	76	38	127	515	SIV063
I	75	16	94	44	150	1000	SIV075
I	90	16	113	51	180	1770	SIV090
I	110	16	137	61	220	2800	SIV110
I	160	16	189	86	207	5020	SIV160

I: IIP 122 H: KIWA K5034 ND 10

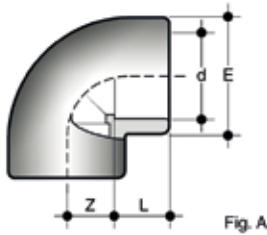

Fig. A

GIV

90° elbow with solvent weld sockets (fig. A)

	d	PN	E	L	Z	g	Code
	12	16	17	12	8	4	GIV012
IFH	16	16	22	14	9	11	GIV016
IFH	20	16	26	16	12	15	GIV020
IFH	25	16	32	19	15	30	GIV025
IFH	32	16	40	22	19	50	GIV032
IFH	40	16	50	26	22	90	GIV040
IFH	50	16	58,5	31	26	107	GIV050
IFH	63	16	73	37,5	32,5	200	GIV063
IF	75	16	87	44	39	315	GIV075
IF	90	16	104	51,5	46,5	533	GIV090
IF	110	16	126	61,5	56,5	930	GIV110
IF	125	16	144	69	64	1330	GIV125
IF	140	16	163	76	77	2080	GIV140
IF	160	16	183	87	82	2820	GIV160
	*180	16	215	96	94	5200	GIV180
	200	**10	222	107	102	4125	GIV200
	225	10	249	119,5	114,5	5670	GIV225

I: IIP 122 F: AFNOR NF04 H: KIWA K5034 ND 10

*Resale product

**PN16 on request

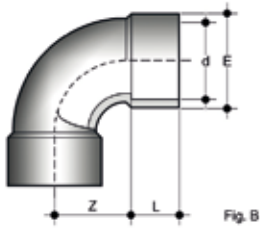

GIV

90° elbow with solvent weld sockets (fig. B)

d	PN	E	L	Z	g	Code
225	*16	258	119	171,5	8700	GIV225
250	10	287	131	188	12480	GIV250
280	10	325	147	210	17000	GIV280
315	10	359	164	236	23370	GIV315

*On request

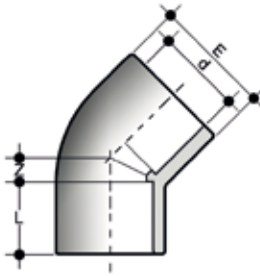

HIV

45° elbow with solvent weld sockets

	d	PN	E	L	Z	g	Code
	12	16	17	12	4	5	HIV012
	16	16	21	14	5	6	HIV016
IFH	20	16	28	16	5,5	20	HIV020
IFH	25	16	33	19	6	26	HIV025
IFH	32	16	41	22	7,5	45	HIV032
IFH	40	16	50	26	10,5	70	HIV040
IFH	50	16	61	31	11,5	120	HIV050
IFH	63	16	76	38	14	200	HIV063
IF	75	16	90	44	17	320	HIV075
IF	90	16	107	51	21,5	550	HIV090
I	110	16	130	61	26	915	HIV110
IF	125	16	147	69	31	1315	HIV125
IF	140	16	163	76	34	1660	HIV140
IF	160	16	192	86	38	3060	HIV160
	*180	10	208	97	38	3500	HIV180
	200	10	230	108	48	4500	HIV200
	225	10	260	121	55	6400	HIV225
	250	10	286	131	58	7700	HIV250
	280	10	320	146	62	10460	HIV280
	315	10	359	164	66	15500	HIV315

I: IIP 122 F: AFNOR NF04 H: KIWA K5034 ND 10
*resale product

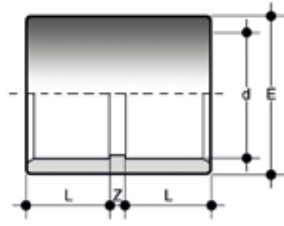

MIV

Solvent weld double socket

	d	PN	E	L	Z	g	Code
	12	16	17	12	3	3	MIV012
F	16	16	21	14	3	7	MIV016
HIF	20	16	26	16	3	11	MIV020
HIF	25	16	32	19	3	20	MIV025
HIF	32	16	40	22	3	30	MIV032
HIF	40	16	50	26	3	55	MIV040
HIF	50	16	61	31	3	90	MIV050
HIF	63	16	76	38	3	160	MIV063
IF	75	16	90	44	3	250	MIV075
IF	90	16	108	51	4	415	MIV090
IF	110	16	131	61	8	715	MIV110
IF	125	16	148	69	7	960	MIV125
IF	140	16	164	76	8	1240	MIV140
IF	160	16	186	86	9	1680	MIV160
	*180	10	209	96	8	2500	MIV180
	200	16	232	106	11	3050	MIV200
	225	16	260	119	11	4600	MIV225
	250	10	286	131	10	5760	MIV250
	280	10	320	146	10	7630	MIV280
	315	10	355	164	12	9780	MIV315

I: IIP 122 F: AFNOR NF04 H: KIWA K5034 ND 10
*resale product

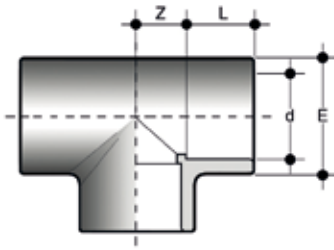

TIV

90° Tee with solvent weld sockets

	d	PN	E	L	Z	g	Code
	12	16	17	12	8	6	TIV012
FH	16	16	22	14	9	15	TIV016
IFH	20	16	27	16	11	25	TIV020
IFH	25	16	33	19	14	40	TIV025
IFH	32	16	40	22	18	65	TIV032
IFH	40	16	49	26	22	114	TIV040
IFH	50	16	58,5	31	26	146	TIV050
IFH	63	16	73	37,5	32,5	275	TIV063
IF	75	16	88	44	39	470	TIV075
IF	90	16	105	52	46	780	TIV090
IF	110	16	127	61	57	1335	TIV110
IF	125	16	151	69	64	2430	TIV125
IF	140	16	174	76	77	4150	TIV140
IF	160	16	183	87	82	3870	TIV160
	*180	16	215	96	94	6180	TIV180
	200	16	228	106	101	6180	TIV200
	225	16	258	119	114	12680	TIV225
	250	10	286	131	128	13250	TIV250
	280	10	319	146	144	17840	TIV280
	315	10	360	164	162	25300	TIV315

I: IIP 122 F: AFNOR NF04 H: KIWA K5034 ND 10
* Resale product

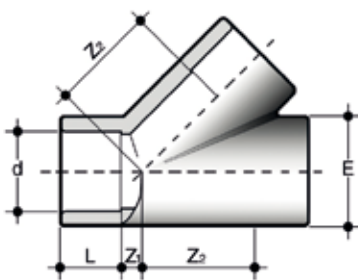

YIV

45° Tee with solvent weld sockets

d	PN	E	L	Z	Z2	g	Code
20	16	27	16	7	30	39	YIV020
25	16	33	19	7	35	62	YIV025
32	16	41	22	9	44	110	YIV032
40	16	51	26	11	55	190	YIV040
50	16	63	31	12	68,5	335	YIV050
63	16	78	38	15	85	570	YIV063
*160	10	189	86	35	200	6500	YIV160

*resale product

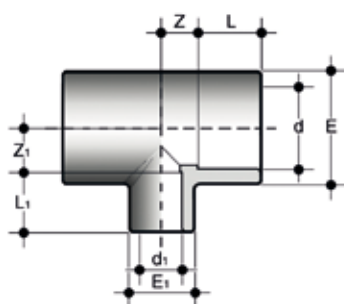

TRIV

90° reducing Tee with reduced branch and solvent weld sockets

d x d ₁	PN	E	E ₁	L	L ₁	Z	Z ₁	g	Code
25 x 20	16	33	28	19	16	14	14	37	TRIV025020
32 x 20	16	41	28	22	16	17,5	17,5	60	TRIV032020
32 x 25	16	41	34	22	19	17,5	17,5	65	TRIV032025
40 x 20	16	50	29	26	16	22	22	100	TRIV040020
40 x 25	16	50	34	26	19	22	22	100	TRIV040025
40 x 32	16	50	42	26	22	22	22	105	TRIV040032
50 x 20	16	61	30	31	16	27	27	160	TRIV050020
50 x 25	16	61	35	31	19	27	27	160	TRIV050025
50 x 32	16	61	42	31	22	27	27	165	TRIV050032
50 x 40	16	61	51	31	26	27	27	170	TRIV050040
63 x 25	16	76	36	38	19	33,5	33,5	290	TRIV063025
63 x 32	16	76	43	38	22	33,5	33,5	295	TRIV063032
63 x 40	16	76	52	38	26	33,5	33,5	300	TRIV063040
63 x 50	16	76	62	38	31	33,5	33,5	315	TRIV063050
75 x 32	16	91	41	44	22	40	40	530	TRIV075032
75 x 40	16	91	50	44	26	40	40	540	TRIV075040
75 x 50	16	91	61	44	31	40	40	550	TRIV075050
75 x 63	16	91	76	44	38	40	40	580	TRIV075063
90 x 40	16	109	50	51	26	48	48	870	TRIV090040
90 x 50	16	109	61	51	31	48	48	880	TRIV090050
90 x 63	16	109	76	51	38	48	48	900	TRIV090063
90 x 75	16	109	91	51	44	48	48	940	TRIV090075
110 x 50	16	133	61	61	31	61	61	1580	TRIV110050
110 x 63	16	133	76	61	38	61	61	1590	TRIV110063
110 x 75	16	133	91	61	44	61	61	1610	TRIV110075
110 x 90	16	133	109	61	51	61	61	1640	TRIV110090
*160 x 110	16	187	131	86	61	82	83	3700	TRIV160110
*250 x 110	10	285	134	129	63	61	128	8300	TRIV250110
*250 x 160	10	285	193	129	87	86	129	9900	TRIV250160
*250 x 200	10	285	228	129	106	133	132	12000	TRIV250200
*280 x 160	10	320	193	146	88	84	153	12500	TRIV280160
*280 x 225	10	320	258	146	117,5	117	150,5	14900	TRIV280225
*315 x 160	8	355	193	164	86	83	161	15000	TRIV315160
*315 x 200	8	355	228	164	106	102	179	17500	TRIV315200
*315 x 250	8	355	285	164	131	127	160	19200	TRIV315250

*resale product

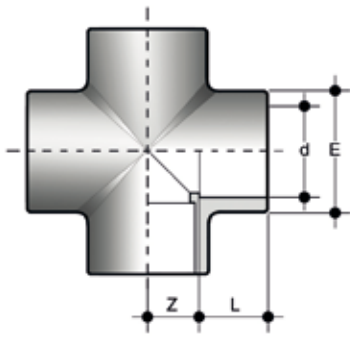

XIV
90° cross with solvent weld sockets

	d	PN	E	L	Z	g	Code
H	25	16	35	19	14	60	XIV025
H	32	16	43	22	18	105	XIV032
H	40	16	52	26	23	175	XIV040
H	50	16	64	31	27	265	XIV050
H	63	16	79	38	33,5	505	XIV063

H: KIWA K5034 ND 10

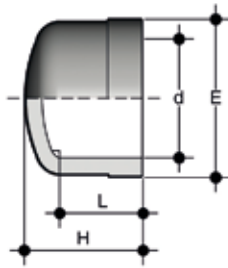

CIV

End cap with solvent weld socket

	d	PN	E	H	L	g	Code
	12	16	17	15	12	3	CIV012
F	16	16	21	17	15	4	CIV016
IF	20	16	28	23	16	9	CIV020
IF	25	16	34	27	19	15	CIV025
IF	32	16	41	31	22	25	CIV032
IF	40	16	51	36	26	40	CIV040
IF	50	16	62	43	31	60	CIV050
IF	63	16	77	51	38	110	CIV063
IF	75	16	91	59	44	190	CIV075
IF	90	16	110	69	51	330	CIV090
IF	110	16	133	85	61	575	CIV110
I	125	16	147	99	69	900	CIV125
	140	16	164	108	76	1100	CIV140
	160	16	192	128	86	1900	CIV160
	225	10	260	163	119	3000	CIV225

I: IIP 122 F: AFNOR NF04

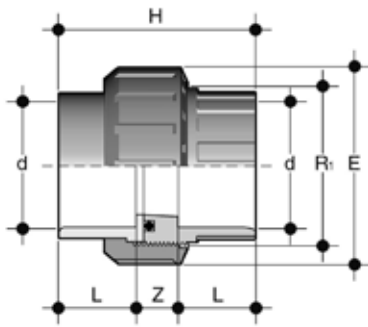

BIV

Union with solvent weld socket, O-Ring in EPDM or FKM

	d	R ₁	PN	E	H	L	Z	g	Code
I	16	3/4"	16	33	41	14	13	20	BIV016E
I	20	1"	16	41	45	16	13	35	BIV020E
I	25	1 1/4"	16	50	51	19	13	60	BIV025E
I	32	1 1/2"	16	58	57	22	13	85	BIV032E
I	40	2"	16	72	67	26	15	150	BIV040E
I	50	2 1/4"	16	79	79	31	17	175	BIV050E
I	63	2 3/4"	16	98	98	38	22	320	BIV063E
	75	3 1/2"	10	120	116	44	21	590	BIV075E
	90	4"	10	135	125	51	23	770	BIV090E
	110	5"	10	163	145	61	23	1300	BIV110E

I: IIP 122

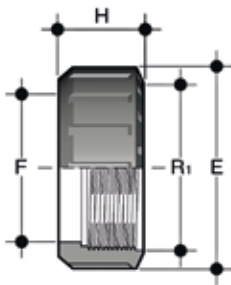

EFV

Union nut with BSP thread for union types BIV, BIFV, BFV, BLV, BIRV, BIFOV, BIROV, BIFXV, BIRXV

R	d BIV	PN	E	F	H	g	Code
1/2"	-	16	27	17	24	8	EFV012
3/4"	16	16	33	22	21	9	EFV034
1"	20	16	41	28	22	13	EFV100
1 1/4"	25	16	50	36	25	22	EFV114
1 1/2"	32	16	58	42	27	30	EFV112
2"	40	16	72	53	30	50	EFV200
2 1/4"	50	16	79	59	34	68	EFV214
2 1/2"	-	16	90	68	36	95	EFV212
2 3/4"	63	16	98	74	38	120	EFV234
3 1/2"	75	10	120	93	45	198	EFV312
4"	90	10	135	106	52	278	EFV400
5"	110	10	163	129	60	448	EFV500

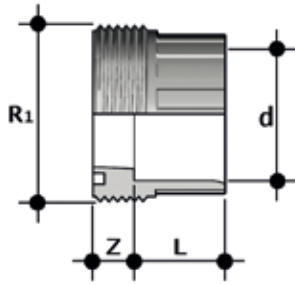

F/BIV

Union bush for solvent welding, metric series for union types BIV, BIFV, BFV, BLV, BIRV, BIFOV, BIROV, BIFXV, BIRXV

d	R ₁	PN	L	Z	g	Code
16	3/4"	16	14	10	9	FBIV016
20	1"	16	16	10	13	FBIV020
25	1 ¹ / ₄ "	16	19	10	25	FBIV025
32	1 ¹ / ₂ "	16	22	10	31	FBIV032
40	2"	16	26	12	58	FBIV040
50	2 ¹ / ₄ "	16	31	14	63	FBIV050
63	2 ³ / ₄ "	16	38	19	119	FBIV063
75	3 ¹ / ₂ "	10	44	18	230	FBIV075
90	4"	10	51	18	290	FBIV090
110	5"	10	61	18	500	FBIV110

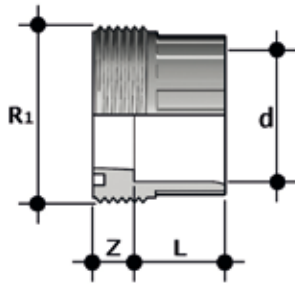

F/BLV

Union bush for solvent welding, series BS for union types BIV, BIFV, BFV, BLV, BIRV, BIFOV, BIROV, BIFXV, BIRXV

d	R ₁	PN	L	Z	g	Code
1/2"	1"	16	16	10	12,5	FBLV012
3/4"	1 ¹ / ₄ "	16	19	10	22,5	FBLV034
1"	1 ¹ / ₂ "	16	22	10	30	FBLV100
1 ¹ / ₄ "	2"	16	26	12	52	FBLV114
1 ¹ / ₂ "	2 ¹ / ₂ "	16	31	14	69,5	FBLV112
2"	2 ³ / ₄ "	16	38	19	133,5	FBLV200

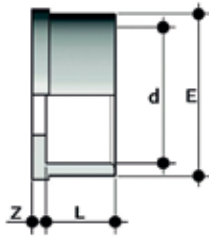

Q/BIV

Union end for solvent welding, metric series for union types BIV, BIFV, BFV, BLV, BIRV, BIFOV, BIROV, BIFXV, BIRXV

d	PN	E	L	Z	g	Code
16	16	22	14	3	5	QBIV016
20	16	28	16	3	8	QBIV020
25	16	36	19	3	15	QBIV025
32	16	42	22	3	24	QBIV032
40	16	53	26	3	37	QBIV040
50	16	59	31	3	42	QBIV050
63	16	74	38	3	77	QBIV063
75	10	93	44	3	150	QBIV075
90	10	105	51	5	192	QBIV090
110	10	129	61	5	335	QBIV110

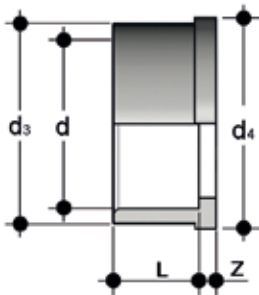

Q/BLV

Union end for solvent welding, BS series for union types BIV, BIFV, BFV, BLV, BIRV, BIFOV, BIROV, BIFXV, BIRXV

d	PN	d ₃	d ₄	L	Z	g	Code
1/2"	16	27,5	30,1	16	3	8	QBLV012
3/4"	16	36	38,8	19	3	13	QBLV034
1"	16	41,5	44,7	22	3	19	QBLV100
1 1/4"	16	53	56,5	26	3	32	QBLV114
1 1/2"	16	59	62,6	31	3	46	QBLV112
2"	16	74	78,4	38	3	86	QBLV200

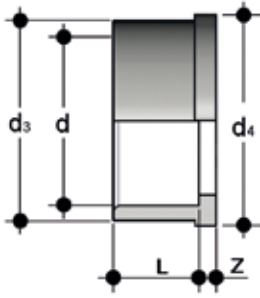

Q/BAV

Union end for solvent welding, ASTM series for union types BIV, BIFV, BFV, BLV, BIRV, BIFOV, BIROV, BIFXV, BIRXV

d	PN	d ₃	d ₄	L	Z	g	Code
1/2"	16	27,5	30,1	22,7	3,5	15,5	QBAV012
3/4"	16	36	38,8	25,9	3,7	22,5	QBAV034
1"	16	41,5	44,7	29,2	3	32,5	QBAV100
1 1/4"	16	53	56,5	32	5	57	QBAV114
1 1/2"	16	59	62,6	35	5	78	QBAV112
2"	16	74	78,4	38,5	5,5	130	QBAV200

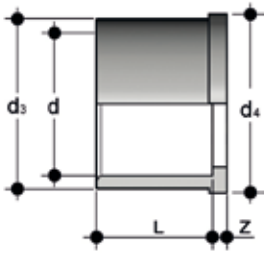

Q/BJV

Union end for solvent welding, JIS series for union types BIV, BIFV, BFV, BLV, BIRV, BIFOV, BIROV, BIFXV, BIRXV

d	PN	d ₃	d ₄	L	Z	g	Code
1/2"	16	27,5	30,1	30	3	16	QBJV012
3/4"	16	36	38,8	35	3,5	21	QBJV034
1"	16	41,5	44,7	40	3	40	QBJV100
1 1/4"	16	53	56,5	44	3	68	QBJV114
1 1/2"	16	59	62,6	55	4,5	105	QBJV112
2"	16	74	78,4	62,9	5,5	175	QBJV200

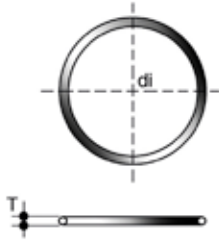

O-RING

O-Ring for union types BIV, BIFV, BFV, BLV, BIRV, BIFOV, BIROV, BIFXV, BIRXV

Union d	C	di	T	d	EPDM code	FKM code
16	3062	15,54	2,62	16	OR3062E	OR3062F
20	4081	20,22	3,53	20	OR4081E	OR4081F
25	4112	28,17	3,53	25	OR4112E	OR4112F
32	4131	32,93	3,53	32	OR4131E	OR4131F
40	6162	40,65	5,34	40	OR6162E	OR6162F
50	6187	47	5,34	50	OR6187E	OR6187F
63	6237	59,69	5,34	63	OR6237E	OR6237F
75	6300	75,57	5,34	75	OR6300E	OR6300F
90	6362	91,45	5,34	90	OR6362E	OR0185F
110	6450	113,67	5,34	110	OR6450E	OR6450F

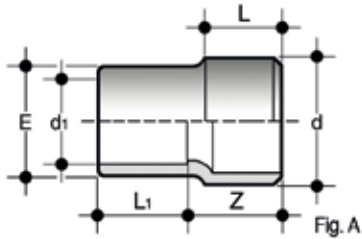

RIV

Reducer: solvent weld spigot (d), solvent weld socket (d1 reduced) (Fig.A)

	d x d ₁	PN	E	L	L ₁	Z	g	Code
I	16 x 12	16	19	14	12	18	7	RIV016012
IF	20 x 16	16	22	16	14	21	8	RIV020016
F	160 x 110	16	137	86	61	125	1270	RIV160110
	200 x 160	10	182	106	86	156	2540	RIV200160

I: IIP 122 F: AFNOR NFO4
RIV: the quality marks refer to dimensions d and d1

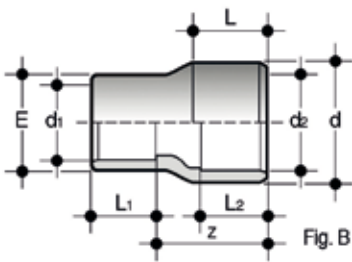

RIV

Reducer: solvent weld spigot (d) or solvent weld socket (d2), solvent weld socket (d1 reduced) (Fig.B)

	d x d ₂ x d ₁	PN	E	L	L ₁	L ₂	Z	g	Code
IF	25 x 20 x 16	16	22	19	14	16	24,5	9	RIV025020016
IF	25 x 20 x 20	16	26	19	16	16	24,5	12	RIV025020020
IF	32 x 25 x 16	16	22	22	14	19	30	14	RIV032025016
IF	32 x 25 x 20	16	27	22	16	19	30	16	RIV032025020
IF	32 x 25 x 25	16	32	22	19	19	30	20	RIV032025025
IF	40 x 32 x 20	16	27	26	16	22	36	23	RIV040032020
IF	40 x 32 x 25	16	32	26	19	22	36	27	RIV040032025
IF	40 x 32 x 32	16	41	26	22	22	36	34	RIV040032032
I	50 x 40 x 20	16	27	31	16	26	44	36	RIV050040020
IF	50 x 40 x 25	16	32	31	19	26	44	40	RIV050040025
IF	50 x 40 x 32	16	40	31	22	26	44	48	RIV050040032
IF	50 x 40 x 40	16	48	31	26	26	44	55	RIV050040040
I	63 x 50 x 25	16	32	38	19	31	54	75	RIV063050025
IF	63 x 50 x 32	16	40	38	22	31	54	80	RIV063050032
IF	63 x 50 x 40	16	49	38	26	31	54	90	RIV063050040
IF	63 x 50 x 50	16	60	38	31	31	54	110	RIV063050050
IF	75 x 63 x 50	16	61	44	31	38	62	130	RIV075063050
IF	75 x 63 x 63	16	76	44	38	38	62	175	RIV075063063
I	110 x 90 x 50	16	61	61	31	51	88	260	RIV110090050
I	110 x 90 x 63	16	76	61	38	51	88	300	RIV110090063
I	110 x 90 x 75	16	89	61	44	51	88	345	RIV110090075
IF	110 x 90 x 90	16	104	61	51	51	88	400	RIV110090090

I: IIP 122 F: AFNOR NFO4
RIV: the quality marks refer to dimensions d and d1

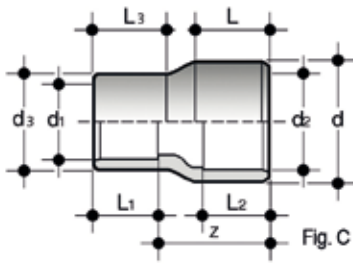

RIV

Reducer: solvent weld spigot (d) or solvent weld socket (d2), solvent weld socket (d1 reduced) or solvent weld spigot (d3 reduced) (Fig.C)

	$d \times d_2 \times d_3 \times d_1$	PN	E	L	L_1	L_2	L_3	Z	g	Code
I	90 x 75 x 50 x 40	16	-	51	26	44	31	74	180	RIV090075050040
IF	90 x 75 x 63 x 50	16	-	51	31	44	38	74	200	RIV090075063050
F	90 x 75 x 75 x 63	16	-	51	38	44	44	74	260	RIV090075075063
	90 x 75 x 90 x 75	16	-	51	44	44	51	74	325	RIV090075090075

I: IIP 122 F: AFNOR NF04
RIV: the quality marks refer to dimensions d and d1

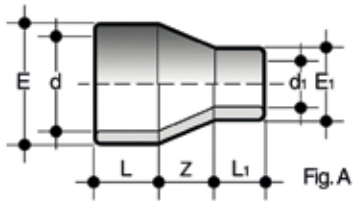

MRIV

Reducer: solvent weld double socket (fig. A)

$d \times d_1$	PN	E	E_1	K	L	L_1	Z	g	Code
*180 x 125	10	214	154	-	95	68	48,8	2700	MRIV180125
*180 x 140	10	214	170	-	95	76	35	2700	MRIV180140
*180 x 160	10	214	190	-	95	86	17	2800	MRIV180160
*200 x 110	10	234	138	-	102	61	78	3100	MRIV200110
*200 x 125	10	234	154	-	102	68	65	3100	MRIV200125
*200 x 140	10	234	170	-	102	76	52	3200	MRIV200140
*200 x 160	10	234	190	-	102	86	35	3200	MRIV200160
*200 x 180	10	234	213	-	102	95	17	3300	MRIV200180
*225 x 110	10	258	138	-	103	62	100	4000	MRIV225110
*225 x 140	10	258	170	-	103	76	74	3800	MRIV225140
*225 x 160	10	258	190	-	103	86	57	4000	MRIV225160
*225 x 180	10	258	214	-	103	95	40	3500	MRIV225180
*225 x 200	10	258	234	-	103	102	22	3500	MRIV225200
*250 x 110	10	283	138	-	105	62	122	4500	MRIV250110
*250 x 125	10	283	154	-	105	68	108	4700	MRIV250125
*250 x 140	10	283	170	-	105	76	96	4600	MRIV250140
*250 x 160	10	283	190	-	105	86	78	4700	MRIV250160
*250 x 180	10	283	214	-	105	95	62	4600	MRIV250180
*250 x 200	10	283	234	-	105	102	44	4500	MRIV250200
*250 x 225	10	283	258	-	105	103	22	4900	MRIV250225
*280 x 110	10	317	138	-	101	62	150	5400	MRIV280110
*280 x 125	10	317	154	-	101	68	136	5400	MRIV280125
*280 x 140	10	317	170	-	101	76	123	5400	MRIV280140
*280 x 160	10	317	190	-	101	86	105	5700	MRIV280160
*280 x 180	10	317	214	-	101	95	87	5700	MRIV280180
*280 x 225	10	317	258	-	101	103	47	5500	MRIV280225
*280 x 250	10	317	283	-	101	105	26	5400	MRIV280250
*315 x 160	8	355	190	-	105	86	135	6400	MRIV315160
*315 x 180	8	355	214	-	105	95	117	6600	MRIV315180
*315 x 200	8	355	234	-	105	102	100	6800	MRIV315200
*315 x 225	8	355	258	-	105	103	79	7200	MRIV315225
*315 x 250	8	355	283	-	105	105	57	6800	MRIV315250
*315 x 280	8	355	317	-	105	101	31	7100	MRIV315280
*355 x 315	5	394	355	-	105	105	35	7500	MRIV355315
*400 x 315	5	435	355	-	105	105	75	9500	MRIV400315
*400 x 355	5	435	394	-	105	105	40	9000	MRIV400355

*resale product

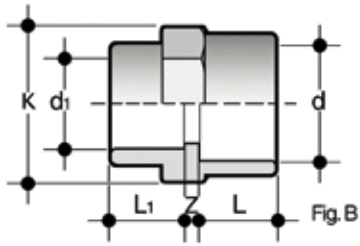

MRIV

Reducer: solvent weld double socket (fig. B)

$d \times d_1$	PN	E	E_1	K	L	L_1	Z	g	Code
110 x 90	16	-	-	130	61	51	4,5	555	MRIV110090

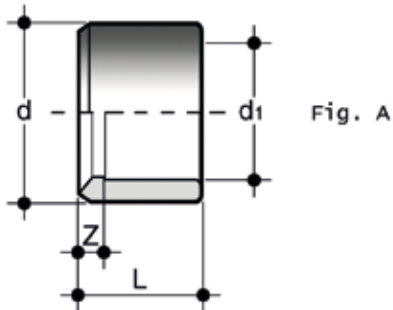

DIV

Reducing bush with solvent weld spigot (d) and solvent weld socket (d1 reduced) (fig. A)

	$d \times d_1$	PN	L	Z	g	Code
	16 x 12	16	14	2	1	DIV016012
IF	20 x 16	16	16	2	3	DIV020016
IF	25 x 20	16	19	3	5	DIV025020
I	32 x 20	16	22	6	15	DIV032020
IF	32 x 25	16	22	3,5	10	DIV032025
IF	40 x 32	16	26	4	17	DIV040032
IF	50 x 40	16	31	5	32	DIV050040
IF	63 x 50	16	38	7	65	DIV063050
IF	75 x 63	16	44	6	85	DIV075063
IF	90 x 75	16	51	7	150	DIV090075
IF	110 x 90	16	61	9	270	DIV110090
IF	125 x 110	16	69	8	285	DIV125110
I	140 x 110	16	76	17	645	DIV140110
IF	140 x 125	16	76	9,5	350	DIV140125
IF	160 x 140	16	86	10	565	DIV160140
	*225 x 200	16	119	13	1380	DIV225200
	250 x 200	10	132	25	3500	DIV250200
	250 x 225	10	132	12	2100	DIV250225
	*280 x 250	10	147	15	2500	DIV280250

I: IIP 122 F: AFNOR NFO4
*resale product

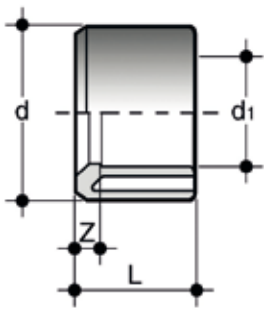

Fig. B

DIV

Reducing bush with solvent weld spigot (d) and solvent weld socket (d1 reduced) (fig. B)

	d x d ₁	PN	L	Z	g	Code
I	40 x 20	16	26	9	25	DIV040020
I	40 x 25	16	26	7	24	DIV040025
I	50 x 32	16	31	8,5	35	DIV050032
I	63 x 32	16	38	16	73	DIV063032
I	63 x 40	16	38	11,5	75	DIV063040
I	75 x 50	16	44	13	120	DIV075050
I	90 x 50	16	51	20	200	DIV090050
I	90 x 63	16	51	13	210	DIV090063
I	110 x 63	16	61	23	340	DIV110063
I	110 x 75	16	61	17	360	DIV110075
I	140 x 90	16	76	25	730	DIV140090
I	160 x 90	16	86	35	1040	DIV160090
I	160 x 110	16	86	24	945	DIV160110
	*180 x 160	10	96	10	710	DIV180160
	*200 x 160	16	106	20	1310	1RRC121000
	*200 x 180	10	106	10	870	DIV200180
	225 x 160	16	119	33	1840	DIV225160
	250 x 160	10	132	45	3100	DIV250160
	*250 x 180	10	132	36	3100	DIV250180
	*250 x 200	10	146	40	4100	DIV280200
	280 x 225	10	147	27	4300	DIV280225
	315 x 200	10	165	58	8650	DIV315200
	315 x 225	10	165	45	8100	DIV315225
	315 x 250	10	165	33	5080	DIV315250

I: IIP 122
*resale product

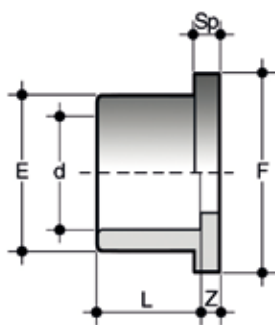

QPV

Flat face stub according to DIN 8063 PN 10/16 with solvent weld socket

	d	DN	PN	E	F	L	Sp	Z	g	Code
I	20	15	16	27	34	16	7	3,5	10	QPV020
I	25	20	16	33	41	19	7	3	16	QPV025
I	32	25	16	41	50	22	7	3	25	QPV032
I	40	32	16	50	61	26	8	3	40	QPV040
I	50	40	16	61	73	31	8	3	62	QPV050
I	63	50	16	76	90	38	9	3	105	QPV063
I	75	65	16	90	105	44	10	3	160	QPV075
I	90	80	16	108	125	51	10	5	275	QPV090
I	110	100	16	131	150	61	12	4	445	QPV110
I	125	125	16	147	168	69	13	5	750	QPV125
I	140	125	16	165	188	76	14	5	790	QPV140
	160	150	16	188	212	86	16	4,5	1140	QPV160
	200	*200	16	230	254	106	18	5,5	1840	QPV200

I: IIP 122

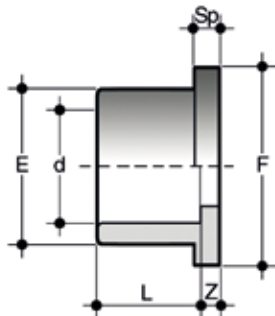

QPV special flat for butterfly valves

Special flat stub in PVC-U for butterfly valve d140 and d225 on d125 and d200 pipe

	d	DN	PN	E	F	L	Sp	Z	g	Code
I	*125	125	16	165	188	69	13	11	760	QPV125FKE
	**200	200	16	248	273	106	30	24	2700	QPV200FKE

*to be used with ODV140 flange
**to be used with ODV225 flange

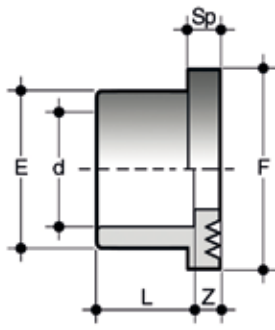

QRV

Serrated face stub according to DIN 8063 PN 10/16 with solvent weld socket, for use with stubs QPV/QRV and flat gasket (for gasket sizes, see QHV)

	d	DN	PN	E	F	L	Sp	Z	g	Code
I	40	32	16	50	61	26	8	3	40	QRV040
I	50	40	16	61	73	31	8	3	62	QRV050
I	63	50	16	76	90	38	9	3	105	QRV063
I	75	65	16	90	105	44	10	3	160	QRV075
I	90	80	16	108	125	51	10	5	275	QRV090
I	110	100	16	131	150	61	12	4	445	QRV110
I	125	125	16	147	168	69	13	5	750	QRV125
I	140	125	16	165	188	76	14	5	790	QRV140
I	160	150	16	188	212	86	16	4,5	1140	QRV160
	200	200	16	230	254	106	18	5,5	1840	QRV200
	225	200	16	245	273	119	25	5,5	1750	QRV225
	250	250	16	270	306	131	20	8,5	2140	QRV250
	280	250	10	307	327	147	32	14,5	3650	QRV280
	315	300	10	346	377	165	32	13	4950	QRV315
	355	350	4	386	413	184	29	8	5400	QRV355
	400	400	4	430	483	206	26	12	6500	QRV400
	450	450	4	486	538	-	19	8	5200	QRV450
	500	500	4	532	574	-	18	-	3000	QRV500

I: IIP 122

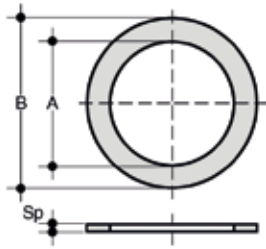

QHV/X

Flat gasket in EPDM and FKM for DIN 2501 and EN 1092 stubs and flanges

d	DN	A	B	Sp	EPDM code	FKM code
16	10	16	27	2	QHVX016E	QHVX016F
20 - 1/2"	15	20	32	2	QHVX020E	QHVX020F
25 - 3/4"	20	24	38,5	2	QHVX025E	QHVX025F
32 - 1"	25	32	48	2	QHVX032E	QHVX032F
40 - 1 1/4"	32	40	59	2	QHVX040E	QHVX040F
50 - 1 1/2"	40	50	71	2	QHVX050E	QHVX050F
63 - 2"	50	63	88	2	QHVX063E	QHVX063F
75 - 2 1/2"	65	75	104	2	QHVX075E	QHVX075F
90 - 3"	80	90	123	2	QHVX090E	QHVX090F
110 - 4"	100	110	148	3	QHVX110E	QHVX110F
125	125	125	166	3	QHVX125E	QHVX125F
140	125	140	186	3	QHVX140E	QHVX140F
160 - 6"	150	160	211	3	QHVX160E	QHVX160F
200	200	200	252	4	QHVX200E	QHVX200F
225 - 8"	200	225	270	4	QHVX225E	QHVX225F
250	250	250	305	4	QHVX250E	QHVX250F

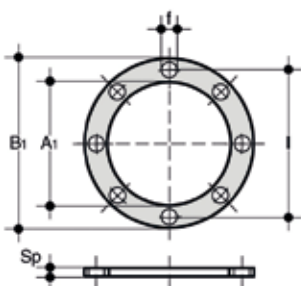

QHV/Y

Self centering gasket in EPDM and FKM for stubs and flanges according to DIN 2501 and DIN 8063

d	DN	A ₁	B ₁	F	I	U	Sp	Code
20 - 1/2"	15	17	95	14	65	4	2	QHVV020E
25 - 3/4"	20	22	107	14	76,3	4	2	QHVV025E
32 - 1"	25	28	117	14	86,5	4	2	QHVV032E
40 - 1" 1/4	32	36	142,5	18	101	4	2	QHVV040E
50 - 1" 1/2	40	45	153,3	18	111	4	2	QHVV050E
63 - 2"	50	57	168	18	125,5	4	2	QHVV063E
75 - 2" 1/2	65	71	187,5	18	145,5	4	3	QHVV075E
90 - 3"	80	84	203	18	160	8	3	QHVV090E
110 - 4"	100	102	223	18	181	8	3	QHVV110E
125	125	132	250	18	210	8	3	QHVV125EDN125
140	125	132	250	18	210	8	3	QHVV140E
160 - 6"	150	152	288.5	22	241,5	8	4	QHVV160E
200	200	192	340	22	295	8	4	QHVV200E
225 - 8"	200	215	340	22	295	8	4	QHVV225E
250	250	238	395	22	350	8	4	QHVV250E
280	250	265	395	22	350	12	4	QHVV280E
315	300	290	462	22	400	12	4	QHVV315E
355	350	337	500	22	460	16	2	QHVV355E
400	400	384	555	22	515	16	2	QHVV400E

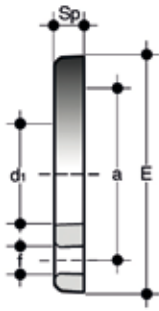

ODV

Backing ring for stubs QPV, QRV, QLV EN/ISO/DIN Drilling: - PN 10/16 up to DN150 - PN 10 from DN200

	d	DN	*MPA (bar)	a	b	d ₁	E	f	Sp	U	** (Nm)	g	Code
I	20	15	10	65	M12 x 70	28	96	14	11	4	<10	60	ODV020
I	25	20	10	75	M12 x 70	34	107	14	12	4	<10	85	ODV025
I	32	25	10	85	M12 x 70	42	117	14	14	4	10	120	ODV032
I	40	32	10	100	M16 x 85	51	143	18	15	4	13	190	ODV040
I	50	40	10	110	M16 x 85	62	153	18	16	4	13	225	ODV050
I	63	50	10	125	M16 x 95	78	168	18	18	4	15	280	ODV063
I	75	65	10	145	M16 x 95	92	188	18	19	4	17	390	ODV075
I	90	80	10	160	M16 x 105	109	203	18	20	8	18	460	ODV090
I	110	100	10	180	M16 x 105	132	222	18	22	8	20	515	ODV110
I	125	125	10	210	M16 x 115	149	250	18	26	8	25	960	ODV125
I	140	125	10	210	M16 x 120	166	251	18	26	8	25	715	ODV140
I	160	150	10	240	M20 x 135	189	290	22	29	8	30	915	ODV160
I	200	200	10	295	M20 x 140	235	340	22	30	8	45	1210	ODV200
I	225	200	10	295	M20 x 140	252	340	22	30	8	50	1090	ODV225
I	250	250	10	350	M20 x 150	278	396	22	34	12	60	1790	ODV250
I	280	250	10	350	M20 x 160	309	396	22	35	12	70	1880	ODV280
I	315	300	10	400	M20 x 180	349	465	22	40	12	50	3050	ODV315
I	355	***350	4	460	M20 x 180	386	505	22	32	16	70	3600	ODV355
I	400	***400	4	515	M20 x 180	434	565	25	33	16	55	4500	ODV400
I	450	***450	4	565	M22 x 160	489	615	25	32	20	65	4400	ODV450
I	500	***500	4	600	M20 x 160	540	650	25	31	20	70	4200	ODV500

I: IIP 122

*PMA maximum admissible working pressure

** nominal tightening torque

***resale product

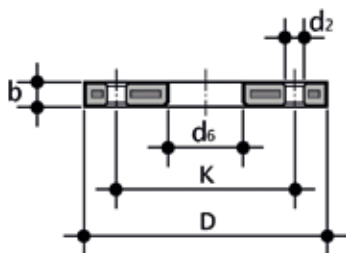

ODB

Steel core backing ring, PP/FRP coated, according to EN/ISO/DIN for stubs QRV, QPV. Drilling: PN 10/16 up to DN 150; PN 10 from DN 200

d	DN	*PMA (bar)	b	D	d ₂	k	M	** (Nm)	n	g	Code
20	15	16	12	28	14	95	M12	10	4	232	ODB020
25	20	16	14	34	14	105	M12	15	4	288	ODB025
32	25	16	14	42	14	115	M12	15	4	544	ODB032
40	32	16	16	51	18	140	M16	20	4	836	ODB040
50	40	16	16	62	18	150	M16	25	4	902	ODB050
63	50	16	19	78	18	165	M16	35	4	1074	ODB063
75	65	16	19	92	18	188	M16	40	4	1368	ODB075
90	80	16	21	109	18	204	M16	40	8	1516	ODB090
***125	100	16	22	135	18	224	M16	50	8	1938	ODB125
****180	150	16	27	191	22	285	M20	60	8	3298	ODB180
200	200	16	28	235	22	240	M20	75	8	5318	ODB200

Maximum pressure values to EN/ISO/DIN. Pay attention to maximum admissible pressure values when selecting gaskets

*PMA: maximum admissible pressure

**nominal tightening torque

*** for use with stubs QPV110, QRV110

**** for use with stubs QPVI60, QRV160

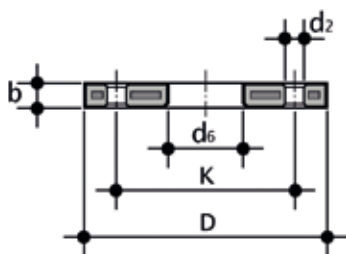

ODB-SW

Steel core backing ring, PP/FRP coated, according to EN/ISO/DIN for stubs QRV and QPV. Drilling: PN 10/16 up to DN 150; PN 10 from DN 200

d	DN	*PMA (bar)	b	D	d ₂	d ₆	k	M	** (Nm)	n	g	Code
140	125	16	24	252	18	166	210	M16	60	8	2965	SWODBD140DN125
225	200	16	27	340	22	248	295	M20	75	8	5060	SWODBD225DN200
280	250	16	30	395	22	309	350	M20	95	12	7112	SWODBD280DN250
315	300	16	34	445	22	349	400	M20	100	12	9468	SWODBD315DN300

*PMA maximum admissible working pressure

**nominal tightening torque

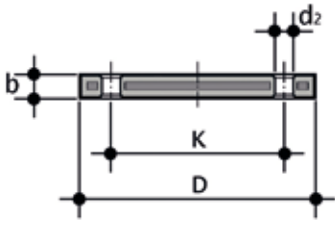

ODBC

Steel core blind ring, PP/FRP coated, according to EN/ISO/DIN for stubs QRV, QPV. Drilling: PN 10/16 up to DN 150; PN 10 from DN 200

d	DN	*PMA (bar)	b	d ₂	D	k	M	n	** (Nm)	g	Code
20	15	10	16	14	95	65	M12	4	15	290	ODBC020S
25	20	10	12	18	105	75	M12	4	15	380	ODBC025S
32	25	10	18	14	115	85	M12	4	15	600	ODBC032S
40	32	10	17	18	140	100	M16	4	25	830	ODBC040S
50	40	10	18	18	150	110	M16	4	35	1105	ODBC050S
63	50	10	18	18	165	125	M16	4	35	1308	ODBC063S
75	65	10	18	18	185	145	M16	4	40	1580	ODBC075S
90	80	10	20	18	200	160	M16	8	40	2244	ODBC090S
110	100	10	20	18	220	180	M16	8	45	2829	ODBC110S
125	100	10	20	18	220	180	M16	8	45	2873	ODBC125S
140	125	10	24	18	250	210	M16	8	50	3920	ODBC140S
160	150	10	22	22	285	240	M20	8	60	7181	ODBC160S
180	150	10	24	22	285	240	M20	8	60	7130	ODBC180S
200	200	10	24	22	340	295	M20	8	70	10580	ODBC200S
225	200	10	24	22	340	295	M20	8	70	10664	ODBC225S
250	250	10	30	22	395	350	M20	12	100	14040	ODBC250S
280	250	10	30	22	395	350	M20	12	100	14040	ODBC280S
315	300	16	34	22	445	400	M20	12	110	26480	ODBC315S

*maximum pressure values according to EN/ISO/DIN. Pay attention to maximum admissible pressure values when selecting gaskets

**nominal tightening torque

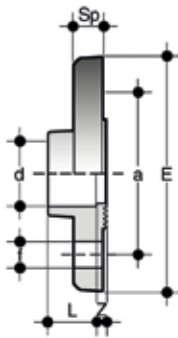

FDV

Fixed flange with solvent weld socket according to EN/ISO/DIN with serrated raised face for flat gaskets (for gasket sizes, see QHV). Drilling: PN 10/16 up to DN 150; PN 10 from DN 200

d	DN	*MPA (bar)	a	E	f	L	** (Nm)	Sp	Z	g	Code
25	20	10	75	105	14	19	<10	12	4,5	105	FDV025
32	25	10	85	115	14	22	10	14	4,5	150	FDV032
40	32	10	100	140	18	26	13	15	4,5	230	FDV040
50	40	10	110	150	18	31	13	16	4,5	280	FDV050
63	50	10	125	163	18	38	15	18	4,5	390	FDV063
75	65	10	145	185	18	44	17	19	5	525	FDV075
90	80	10	160	200	18	51	18	20	7	710	FDV090
110	100	10	180	220	18	61	20	22	8	955	FDV110

*MPA: maximum admissible pressure

**nominal tightening torque

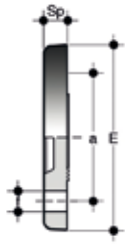

FCV

Blind flange drilled according to EN/ISO/DIN with serrated raised face for flat gaskets (for gasket sizes, see QHV). Drilling: PN 10/16 up to DN 175; PN 10 from DN 200

d	DN	*MPA (bar)	a	E	f	** (Nm)	Sp	U	g	Code
25	20	10	75	105	14	<10	12	4	95	FCV025
32	25	10	85	115	14	10	14	4	135	FCV032
40	32	10	100	141	18	13	15	4	225	FCV040
50	40	10	110	150	18	13	16	4	270	FCV050
63	50	10	125	165	18	15	18	4	355	FCV063
75	65	10	145	186	18	17	19	4	510	FCV075
90	80	10	160	201	18	18	20	8	675	FCV090
110	100	10	180	221	18	20	22	8	915	FCV110
180	***175	10	270	315	22	45	30	8	3100	FCV180
200-225	***200	10	295	340	22	60	30	8	3800	FCV200

Surface with roughness deriving from the phonographic trace of the turning

*MPA: maximum admissible pressure

**nominal tightening torque

***resale product

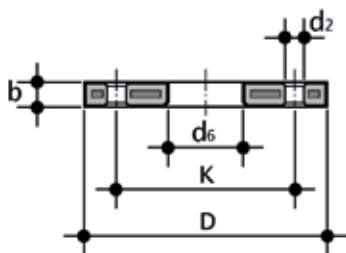

OAB

Steel core backing ring, PP/FRP coated, according to ANSI B16.5 cl.150 for stubs QRV, QPV

Inch	DN	*MPA (bar)	b	D	d2 mm	d ₂ inch	d ₆	kmm	k inch	** (Nm)	n	g	Code
1/2"	20	16	12	95	16	5/8"	28	60,4	2"3/8	15	4	200	OAB012
3/4"	25	16	12	102	16	5/8"	34	69,7	2"3/4	15	4	240	OAB034
1"	32	16	16	114	16	5/8"	42	79,2	3"1/8	15	4	490	OAB100
1"1/4	40	16	16	130	16	5/8"	51	88,7	3"1/2	25	4	670	OAB114
1"1/2	50	16	18	133	16	5/8"	62	98,3	3"7/8	35	4	640	OAB112
2"	63	16	18	162	20	3/4"	78	120,0	4"3/4	35	4	1000	OAB200
2"1/2	75	16	18	184	20	3/4"	92	139,7	5"1/2	40	4	1310	OAB212
3"	90	16	18	194	20	3/4"	111	152,4	6"	40	4	1250	OAB300
4"	110	16	18	229	20	3/4"	133	190,6	7"1/2	40	8	1660	OAB400

* MPA: maximum admissible working pressure
**nominal tightening torque

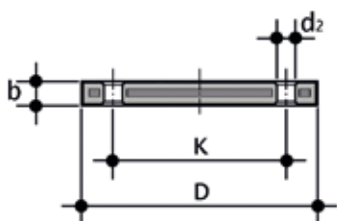

OABC

Steel core blind flange, PP/FRP coated, according to ANSI B16.5 cl.150

inch	DN	*MPA (bar)	B	D	d2 mm	d ₂ inch	Kmm	Kinch	** (Nm)	n	g	Code
1/2"	15	16	12	95	16	5/8"	60,45	2"3/8	15	4	200	OABC012
3/4"	20	16	12	102	16	5/8"	69,85	2"3/4	15	4	240	OABC034
1"	25	16	16	114	16	5/8"	79,25	3"1/8	15	4	370	OABC100
1"1/4	32	16	16	130	16	5/8"	88,90	3"1/2	25	4	530	OABC114
1"1/2	40	16	18	133	16	5/8"	98,55	3"7/8	35	4	560	OABC112
2"	50	16	18	162	20	3/4"	120,65	4"3/4	35	4	810	OABC200
2"1/2	65	16	18	184	20	3/4"	139,70	5"1/2	40	4	1070	OABC212
3"	80	16	18	194	20	3/4"	152,40	6"	40	4	1030	OABC300
4"	100	16	18	229	20	3/4"	190,50	7"1/2	40	8	1570	OABC400

* MPA: maximum admissible working pressure
**nominal tightening torque

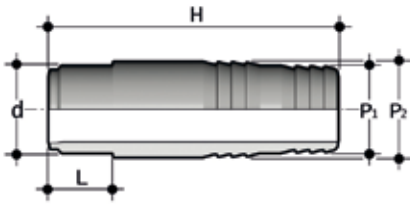

AIV

Hose adaptor with solvent weld spigot

d x P ₂ x P ₁	PN	H	L	g	Code
12 x 14 x 12	16	56	12	6	AIV012014012
16 x 18 x 16	16	60	14	12	AIV016018016
20 x 22 x 20	16	67	16	17	AIV020022020
25 x 27 x 25	16	81	19	26	AIV025027025
32 x 32 x 30	16	98	22	40	AIV032032030
40 x 42 x 40	16	104	26	78	AIV040042040
50 x 52 x 50	16	111	31	113	AIV050052050
63 x 64 x 60	16	123	38	170	AIV063064060

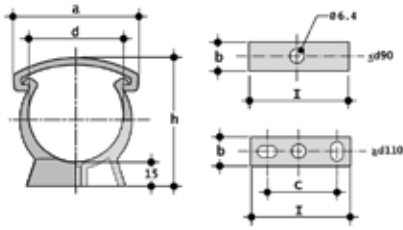

ZIKM

Pipe clip for ISO-DIN pipes in PP*

d	a	b	C	h	l	Code
16	26	18	-	33	16	ZIKM016
20	33	14	-	38	20	ZIKM020
25	41	14	-	44	25	ZIKM025
32	49	15	-	51	32	ZIKM032
40	58	16	-	60	40	ZIKM040
50	68	17	-	71	60	ZIKM050
63	83	18	-	84	63	ZIKM063
75	96	19	-	97	75	ZIKM075
90	113	20	-	113	90	ZIKM090
110	139	23	40	134	125	ZIKM110
125	158	25	60	151	140	ZIKM125
140	177	27	70	167	155	ZIKM140
160	210	30	90	190	180	ZIKM160
180	237	33	100	211	200	ZIKM180

*for pipe support systems, refer to guidelines DVS 2210-1 (Planning and execution - above-ground pipe systems)

**resale product

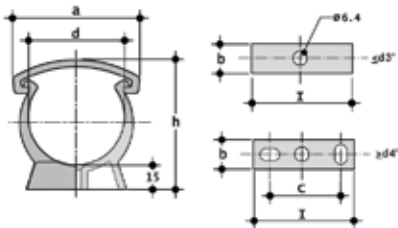

ZAKM

Pipe clip for ASTM pipes in PP*

d	a	b	C	h	l	Code
**3/8"	26	13	-	34	16	ZAKM038
**1/2"	33	14	-	39	20	ZAKM012
**3/4"	41	14	-	45	25	ZAKM034
**1"	49	15	-	52	32	ZAKM100
**1 1/4"	58	16	-	61	40	ZAKM114
**1 1/2"	68	17	-	67	50	ZAKM112
**2"	83	18	-	80	63	ZAKM200
**2 1/2"	96	19	-	96	75	ZAKM212
**3"	118	20	-	110	90	ZAKM300
**4"	140	25	60	135	140	ZAKM400
**6"	197	30	90	196	180	ZAKM600

*for pipe support systems, refer to guidelines DVS 2210-1 (Planning and execution - above-ground pipe systems)

**resale product

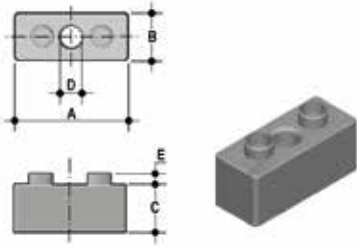

DSM

Distance plates in PP for ZIKM pipe clips*

d	A	B	C	D	E	Pack	Master	Code
32	33	16	14	8	4	20	120	DSM032
40	41	17	17	8	4	10	80	DSM040
50	51	18	17	8	4	10	50	DSM050
63	64	19	22,5	8	4	10	40	DSM063
75	76	20	34,5	8	4	10	40	DSM075

*for pipe support systems, refer to guidelines DVS 2210-1 (Planning and execution - above-ground pipe systems)

**resale product

INSTALLATION

POSITIONING OF ZIKM AND ZAKM PIPE CLIPS

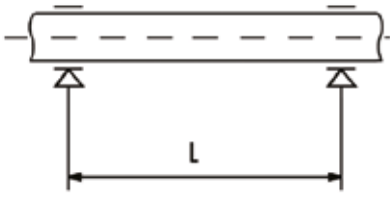

The installation of thermoplastic pipe systems requires the use of support clips to prevent flexing and the resulting mechanical stresses.

The distance between the clips depends on the pipe material, SDR, surface temperature and the density of the conveyed fluid.

Before installing the clips, check the distances reported in the table below, as provided for by guidelines DVS 2210-01 for water pipes.

Supporting PVC-U pipes conveying liquids of density 1 g/cm³ (water and other fluids of equal intensity).

For pipes of PN 16:

d mm	< 20° C	30° C	40° C	50° C	60° C
16	950	900	850	750	600
20	1100	1050	1000	900	700

For pipes of PN 10:

d mm	< 20° C	30° C	40° C	50° C	60° C
25	1200	1150	1050	950	750
32	1350	1300	1250	1100	900
40	1450	1400	1350	1250	1000
50	1600	1550	1500	1400	1150
63	1800	1750	1700	1550	1300
75	2000	1900	1850	1700	1450
90	2200	2100	2000	1850	1550
110	2400	2300	2250	2050	1750
125	2550	2450	2400	2200	1850
140	2700	2600	2500	2300	1950
160	2900	2800	2700	2500	2100
180	3100	2950	2850	2650	2200

For different SDR values, multiply the data in the table by the following factors:

1.08 for SDR 13.6 / S6.3 / PN16 size range d25 - d400

1.15 for SDR 11 / S5 / PN20 entire size range

Supporting PVC-U pipes conveying liquids of density other than 1 g/cm³

If the liquid being conveyed has a density other than 1 g/cm³, the distance L in the table must be multiplied by the factors in the table below.

Fluid density in g/cm ³	Support factor
1,25	0,96
1,50	0,92
< 0,01	1.42 for SDR 21 / S10 / PN10 1.30 for SDR 13.6 / S6.3 / PN16 1.20 for SDR 11 / S5 / PN20



ISO-BSP FITTINGS

PVC-U

Adaptor fittings



ISO-BSP FITTINGS

Series of fittings designed for conveying fluids under pressure with threaded and solvent weld cold chemical jointing systems (solvent welding) using suitable solvent cement and cleaner/primer.

ADAPTOR FITTINGS

Technical specifications	
Size range	d 16 ÷ d 125 (mm): R 3/8" ÷ 4"
Nominal pressure	PN 16 with water at 20 °C
Temperature range	0 °C ÷ 60 °C
Coupling standards	Solvent welding: ISO 727, EN ISO 15493, DIN 8063, EN ISO 1452, ASTM D 2467, JIS K 6743, BS 4346-1. Can be coupled to pipes according to ISO 161-1, EN ISO 1452, EN ISO 15493, DIN 8062, ASTM D1785, JIS K6741, BS 3505-3506 Thread: UNI ISO 228-1, DIN 2999, BS 21, ISO 7, ASTM D 2464, JIS B 0203
Reference standards	Construction criteria: EN ISO 1452, EN ISO 15493 Test methods and requirements: EN ISO 1452, EN ISO 15493 Installation criteria: DVS 2204, DVS 2221, UNI 11242
Fitting material	PVC-U Grey RAL 7011
Seal material	EPDM, FKM

TECHNICAL DATA

PRESSURE VARIATION ACCORDING TO TEMPERATURE

For water and non-hazardous fluids for which the material is classified as CHEMICALLY RESISTANT (life expectancy 25 years). In other cases, a reduction of the nominal pressure PN is required.

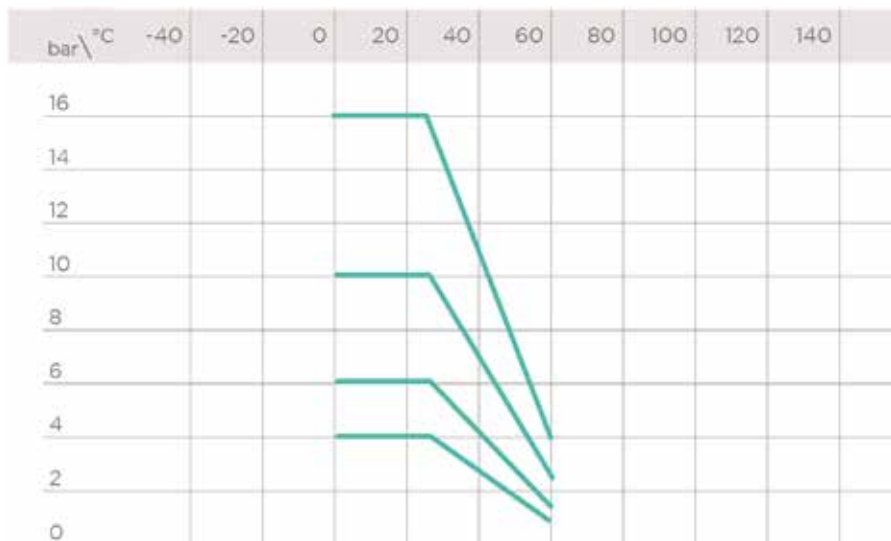

REGRESSION CURVE FOR PVC-U FITTINGS

Regression coefficients according to EN ISO 1452 and EN ISO 15493 for MRS (minimum required strength) values = 25 N/mm² (MPa) (classification PVC-U 250)

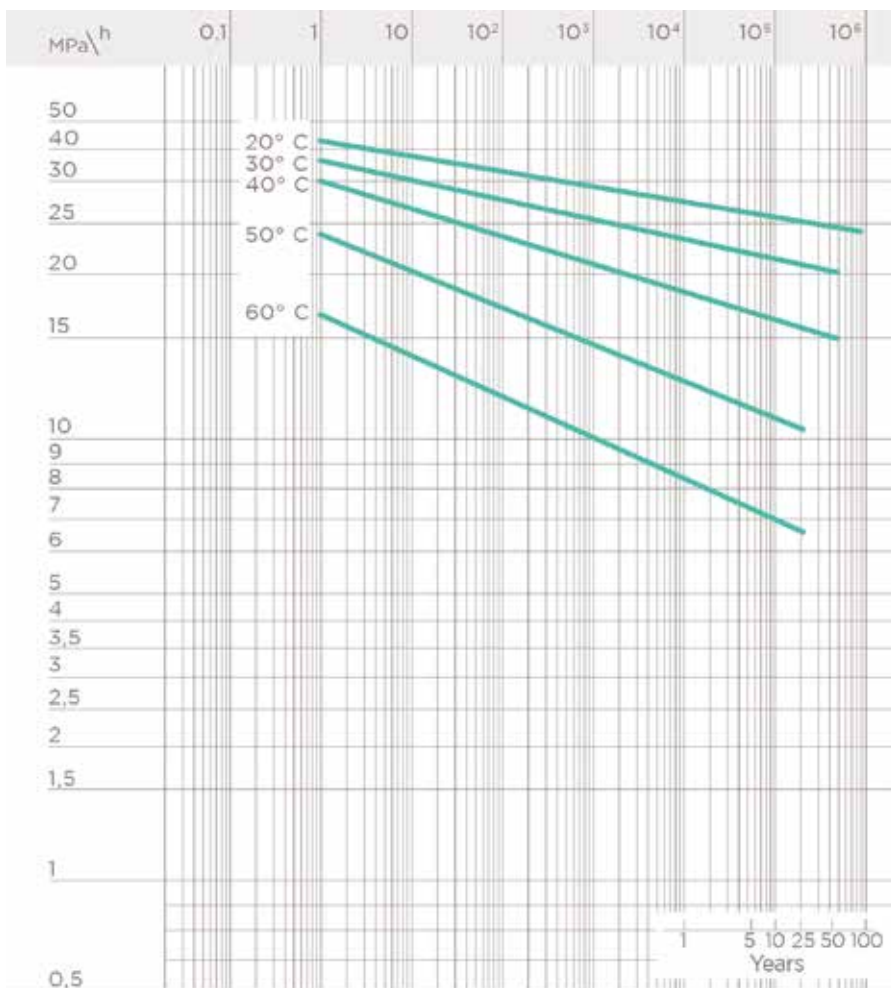

SAFETY FACTORS

Nominal pressure PN must be understood as being the standard pressure used for calculating and selecting the required fittings. In order to be able to comply with the safety factors, the maximum continuous working pressure at 20° C when conveying water must be the same as the nominal pressure values. Unless otherwise specified, the nominal pressures are as follows:

- solvent weld fittings from d 12 to d 225 PN 16 from d 250 to d 315 PN 10
- adaptor fittings from d 16 to d 110 PN 16
- threaded fittings from R 3/8" to R 4" up to PN 16.

Pe (bar)	1h	1000h	50 years	T
10	6,72	5,12	4	
16	4,2	3,2	2,5	

DIMENSIONS

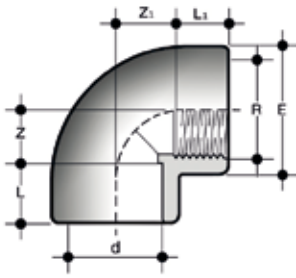

GIFV

90° elbow with solvent weld socket and BSP threaded female end R

d x R	PN	E	L	L ₁	Z	Z ₁	g	Code
16 x 3/8"	16	23,5	14	11,4	10	13	16	GIFV016038
20 x 1/2"	16	28,5	16	15	12	13	24	GIFV020012
25 x 3/4"	16	35	19	16,3	14	17	40	GIFV025034
32 x 1"	16	43	22	19,1	18	20,5	72	GIFV032100
40 x 1 1/4"	16	54	26	21,4	22,5	27	125	GIFV040114
50 x 1 1/2"	16	61	31	21,4	27	37	175	GIFV050112
63 x 2"	16	76	38	25,7	33	46	320	GIFV063200
75 x 2 1/2"	16	91	44	30,2	40,5	55	465	GIFV075212
90 x 3"	16	108	51	33,3	48	65,5	795	GIFV090300
110 x 4"	16	131	61	39,3	60	80	1130	GIFV110400

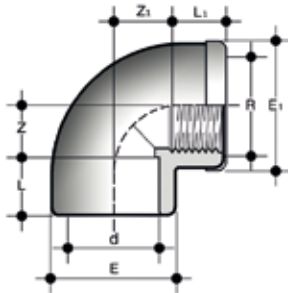

GIMV

90° elbow with reinforced solvent weld socket d and BSP threaded female end R with stainless steel reinforcing ring

d x R	PN	E	E ₁	L	L ₁	Z	Z ₁	g	Code
16 x 3/8"	16	23,5	24,5	14	11,4	10	13	20	GIMV016038
20 x 1/2"	16	28,5	29,5	16	15	12	13	30	GIMV020012
25 x 3/4"	16	35	36	19	16,3	14	17	48	GIMV025034
32 x 1"	16	43	44	22	19,1	18	20,5	85	GIMV032100
40 x 1 1/4"	16	54	55	26	21,4	22,5	27	130	GIMV040114
50 x 1 1/2"	16	61	62	31	21,4	27	37	185	GIMV050112
63 x 2"	16	76	77	38	25,7	33	46	345	GIMV063200

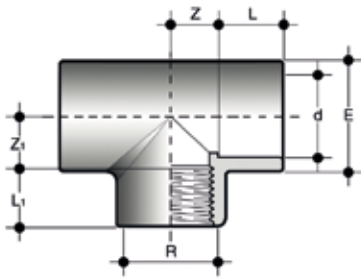

TIFV

90° Tee with solvent weld socket d and BSP threaded female end R

d x R	PN	E	L	L ₁	Z	Z ₁	g	Code
16 x 3/8"	16	23,5	14	11,4	9	11	20	TIFV016038
20 x 1/2"	16	28,5	16	15	12	13	32	TIFV020012
25 x 3/4"	16	35	19	16,3	15	17	52	TIFV025034
32 x 1/2"	16	41	22	15	17,5	18	92	TIFV032012
32 x 1"	16	43	22	19,1	18	21	71	TIFV032100
40 x 1 1/4"	16	50	26	21,4	21,5	27	110	TIFV040114
50 x 1/2"	16	61	31	15	27	27,5	160	TIFV050012
50 x 1 1/2"	16	61	31	21,4	27	37	195	TIFV050112
63 x 1/2"	16	76	38	15	33,5	37,5	305	TIFV063012
63 x 2"	16	76	38	25,7	33,5	46	405	TIFV063200
75 x 2 1/2"	16	91	44	30,2	41	54,5	605	TIFV075212
90 x 3"	16	109	51	33,3	48,5	66	1070	TIFV090300
110 x 4"	16	103	61	39,3	61,5	83	1690	TIFV110400

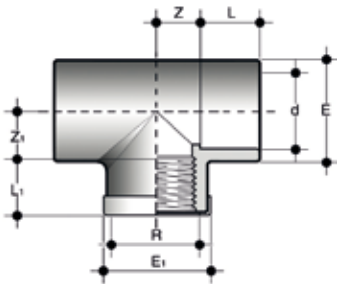

TIMV

90° Tee with reinforced end: solvent weld socket d and BSP threaded female branch R with stainless steel reinforcing ring

d x R	PN	E	E ₁	L	L ₁	Z	Z ₁	g	Code
16 x 3/8"	16	23,5	24,5	14	11,4	9	11	24	TIMV016038
20 x 1/2"	16	28,5	29	16	15	12	13	38	TIMV020012
25 x 3/4"	16	35	36	19	16,3	15	17	60	TIMV025034
32 x 1"	16	43	44	22	19,1	18	21	105	TIMV032100
40 x 1 1/4"	16	50	51	26	21,4	21,5	27	125	TIMV040114
50 x 1 1/2"	16	61	62	31	21,4	27	37	210	TIMV050112
63 x 2"	16	76	77	38	25,7	33,5	46	415	TIMV063200

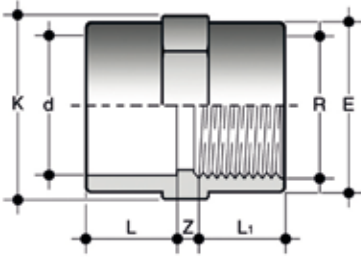

MIFV

Double socket with solvent weld socket d and BSP threaded female end R

d x R	PN	E	K	L	L ₁	Z	g	Code
16 x 3/8"	16	23,5	24	14	11,4	5,5	12	MIFV016038
20 x 1/2"	16	28,5	29	16	15	4	20	MIFV020012
25 x 3/4"	16	35	35	19	16,3	5	30	MIFV025034
32 x 1"	16	43	43	22	19,1	6	48	MIFV032100
40 x 1 1/4"	16	50	50	26	21,4	5	56	MIFV040114
50 x 1 1/2"	16	61	61	31	21,4	8	102	MIFV050112
63 x 2"	16	76	76	38	25,7	7,5	181	MIFV063200

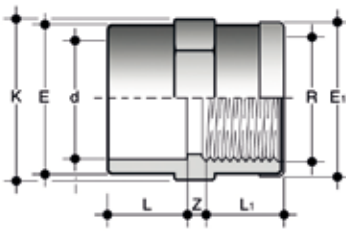

MIMV

Double socket with solvent weld socket d and BSP threaded female end R with stainless steel reinforcing ring

d x R	PN	E	E ₁	K	L	L ₁	Z	g	Code
16 x 3/8"	16	23,5	24,5	24	14	11,4	5,5	14	MIMV016038
20 x 1/2"	16	28,5	29,5	29	16	15	4	23	MIMV020012
25 x 3/4"	16	35	36	35	19	16,3	5	34	MIMV025034
32 x 1"	16	43	44	43	22	19,1	6	53	MIMV032100
40 x 1 1/4"	16	50	51	50	26	21,4	5	62	MIMV040114
50 x 1 1/2"	16	61	62	61	31	21,4	8	110	MIMV050112
63 x 2"	16	76	77	76	38	25,7	7,5	190	MIMV063200

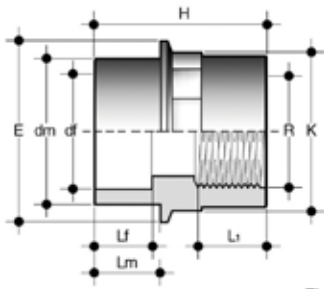

Fig. A

DIFV

Double adaptor with solvent weld socket df , solvent weld spigot dm and BSP threaded female end R (fig. A)

$dm \times df \times R$	PN	E	H	K	L_1	L_f	L_m	g	Code
20 x 16 x 3/8"	16	28	36	24	11,4	14	16	11	DIFV020016038
25 x 20 x 1/2"	16	34	42	29	15	16	19	17	DIFV025020012
32 x 25 x 3/4"	16	40	49	35	16,3	19	22	26	DIFV032025034
40 x 32 x 1"	16	52	57	44	19,1	22	26	49	DIFV040032100
50 x 40 x 1 1/4"	16	59	67	54	21,4	26	31	66	DIFV050040114
63 x 50 x 1 1/2"	16	70	77	64	21,4	31	38	129	DIFV063050112

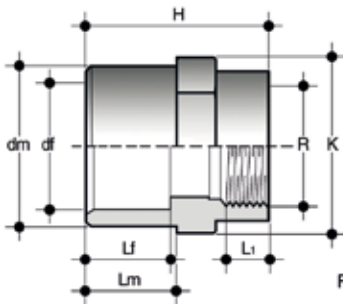

Fig. B

DIFV

Double adaptor with solvent weld socket df , solvent weld spigot dm and BSP threaded female end R (fig. B)

$dm \times df \times R$	PN	E	H	K	L_1	L_f	L_m	g	Code
20 x 16 x 1/2"	16	-	39	30	15	14	16	18	DIFV020016012
25 x 20 x 3/4"	16	-	45	36	16,3	16	19	28	DIFV025020034
32 x 25 x 1"	16	-	51	46	19,1	19	22	49	DIFV032025100
40 x 32 x 1 1/4"	16	-	62	54	21,4	22	26	74	DIFV040032114
50 x 40 x 1 1/2"	16	-	72	65	21,4	26	31	127	DIFV050040112
63 x 50 x 2"	16	-	86	80	25,7	31	38	190	DIFV063050200
75 x 63 x 2"	16	-	76	76	25,7	38	44	180	DIFV075063200
75 x 63 x 2 1/2"	16	-	99	95	30,2	38	44	280	DIFV075063212
90 x 75 x 2 1/2"	16	-	84	95	30,2	44	51	300	DIFV090075212
90 x 75 x 3"	16	-	114	110	33,3	44	51	470	DIFV090075300
110 x 90 x 3"	16	-	100	110	33,3	51	61	450	DIFV110090300
110 x 90 x 4"	16	-	134	130	39,3	51	61	670	DIFV110090400
125 x 110 x 4"	16	-	111	131	39,3	61	69	550	DIFV125110400

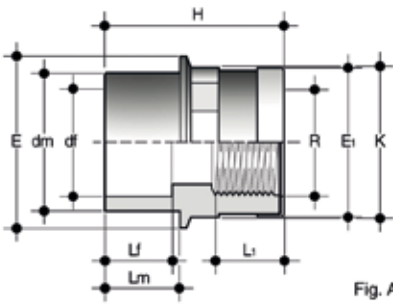

Fig. A

DIMV

Double adaptor with solvent weld socket df, solvent weld spigot dm and BSP threaded female end R with stainless steel reinforcing ring (fig. A)

dm x df x R	PN	E	E ₁	H	K	L ₁	L _f	L _m	g	Code
20 x 16 x 3/8"	16	28	24,5	37	24	11,4	14	16	13	DIMV020016038
25 x 20 x 1/2"	16	34	29,5	43	29	15	16	19	20	DIMV025020012
32 x 25 x 3/4"	16	40	36	50	35	16,3	19	22	32	DIMV032025034
40 x 32 x 1"	16	52	44	58	44	19,1	22	26	58	DIMV040032100
50 x 40 x 1 1/4"	16	59	55	68	54	21,4	26	31	77	DIMV050040114
63 x 50 x 1 1/2"	16	70	62	78	64	21,4	31	38	143	DIMV063050112

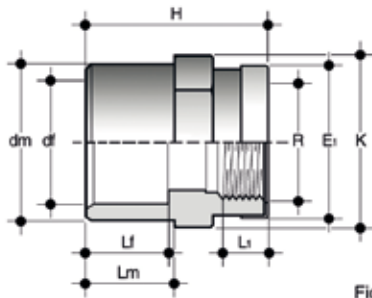
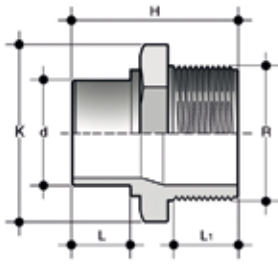

Fig. B

DIMV

Double adaptor with solvent weld socket df, solvent weld spigot dm and BSP threaded female end R with stainless steel reinforcing ring (fig. B)

dm x df x R	PN	E	E ₁	H	K	L ₁	L _f	L _m	g	Code
20 x 16 x 1/2"	16	-	29,5	40	30	15	14	16	21	DIMV020016012
25 x 20 x 3/4"	16	-	36	46	36	16,3	16	19	34	DIMV025020034
32 x 25 x 1"	16	-	44	52	46	19,1	19	22	58	DIMV032025100
40 x 32 x 1 1/4"	16	-	55	63	54	21,4	22	26	85	DIMV040032114
50 x 40 x 1 1/2"	16	-	62	73	65	21,4	26	31	141	DIMV050040112
63 x 50 x 2"	16	-	77	87	80	25,7	31	38	212	DIMV063050200
75 x 63 x 2"	16	-	77	77	76	25,7	38	44	202	DIMV075063200



NRIV

Barrel nipple with reduced solvent weld spigot d and BSP threaded male end R

d x R	PN	E	H	K	L	g	Code
25 x 1"	16	53	60	46	26	43	NRIV025100
32 x 1 1/4"	16	63	66	55	28	70	NRIV032114

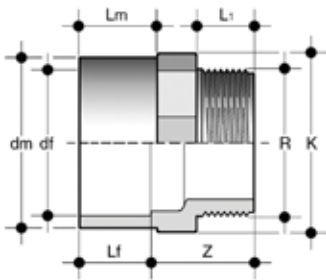

KIFV

Double adaptor with solvent weld socket df, solvent weld spigot dm and BSP threaded male end R

dm x df x R	PN	K	L ₁	L _m	L _f	Z	g	Code
16 x 12 x 3/8"	16	19	11.4	14	12	22	4	KIFV016012038
20 x 16 x 3/8"	16	24	11.4	16	14	25.5	6	KIFV020016038
20 x 16 x 1/2"	16	24	15	16	14	30	15	KIFV020016012
25 x 20 x 1/2"	16	30	15	19	16	30	15	KIFV025020012
25 x 20 x 3/4"	16	30	16.3	19	16	31	20	KIFV025020034
32 x 25 x 1/2"	16	36	15	22	19	30	25	KIFV032025012
32 x 25 x 3/4"	16	36	16.3	22	19	31.5	25	KIFV032025034
32 x 25 x 1"	16	36	19.1	22	19	34	45	KIFV032025100
40 x 32 x 3/4"	16	46	16.3	26	22	32	40	KIFV040032034
40 x 32 x 1"	16	46	19.1	26	22	35	40	KIFV040032100
40 x 32 x 1 1/4"	16	46	21.4	26	22	37	55	KIFV040032114
50 x 40 x 1"	16	55	19.1	31	26	38	70	KIFV050040100
50 x 40 x 1 1/4"	16	55	21.4	31	26	40.5	70	KIFV050040114
50 x 40 x 1 1/2"	16	55	21.4	31	26	40.5	70	KIFV050040112
63 x 50 x 1 1/4"	16	65	21.4	38	31	42.5	70	KIFV063050114
63 x 50 x 1 1/2"	16	65	21.4	38	31	42.5	115	KIFV063050112
63 x 50 x 2"	16	65	25.7	38	31	47	125	KIFV063050200
75 x 63 x 1 1/2"	16	75	21.4	44	38	41	198	KIFV075063112
75 x 63 x 2"	16	75	25.7	44	38	46	160	KIFV075063200
75 x 63 x 2 1/2"	16	80	30.2	44	38	52.5	195	KIFV075063212
90 x 75 x 2"	16	95	25.7	51	44	49	275	KIFV090075200
90 x 75 x 2 1/2"	16	95	30.2	51	44	54	280	KIFV090075212
90 x 75 x 3"	16	95	33.5	51	44	56	300	KIFV090075300
110 x 90 x 2 1/2"	16	110	30.2	61	51	57	370	KIFV110090212
110 x 90 x 3"	16	110	33.5	61	51	62	390	KIFV110090300
110 x 90 x 4"	16	128	39.2	61	51	77	420	KIFV110090400
125 x 110 x 3"	16	128	33.5	69	61	59	450	KIFV125110300
125 x 110 x 4"	16	128	39.2	69	61	65	500	KIFV125110400

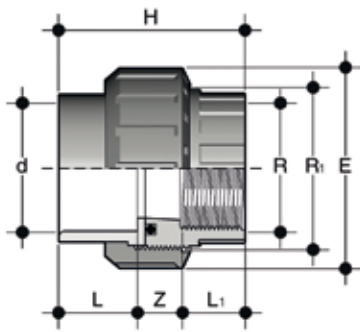

BIFV

Union with solvent weld socket d and BSP threaded female end R with O-Ring in EPDM

d x R	R ₁	PN	E	H	L	L ₁	Z	g	Code
16 x 3/8"	3/4"	16	33	41	14	11,4	15,6	22	BIFV016038E
20 x 1/2"	1"	16	41	45	16	15	14	35	BIFV020012E
25 x 3/4"	1 1/4"	16	50	51	19	16,3	15,7	62	BIFV025034E
32 x 1"	1 1/2"	16	58	57	22	19,1	15,9	85	BIFV032100E
40 x 1 1/4"	2"	16	72	67	26	21,4	19,6	145	BIFV040114E
50 x 1 1/2"	2 1/4"	16	79	72	31	21,4	19,6	180	BIFV050112E
63 x 2"	2 3/4"	16	98	88	38	25,7	24	315	BIFV063200E
75 x 2 1/2"	3 1/2"	10	120	116	44	30,2	34,8	630	BIFV075212E
90 x 3"	4"	10	135	125	51	33,3	40,7	810	BIFV090300E
110 x 4"	5"	10	163	145	61	39,3	44,7	1350	BIFV110400E

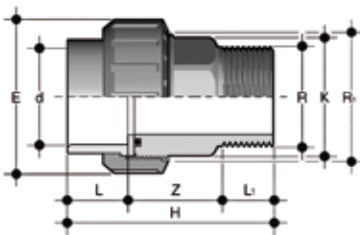

BIRV

Union with fixed BSP threaded male end and O-Ring in EPDM

d x R	R ₁	PN	E	H	K	L	L ₁	Z	g	Code
50 x 1 1/2"	2 1/4"	16	79	98	53	31	21,4	45,6	200	BIRV050112E
50 x 2"	2 1/4"	16	79	102	53	31	25,7	45,3	220	BIRV050200E
63 x 2"	2 3/4"	16	98	116	67	38	25,7	52,3	380	BIRV063200E

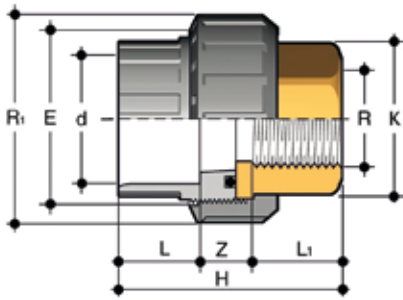

BIFOV

Adaptor union in PVC-U/brass with solvent weld socket d and BSP threaded brass female end R with O-Ring in EPDM

d x R	R ₁	PN	E	H	K	L	L ₁	Z	g	Code
16 x 3/8"	3/4"	16	33	45,5	20	14	13,5	18	53	BIFOV016038E
20 x 1/2"	1"	16	41	48,5	25	16	16,5	16	86	BIFOV020012E
25 x 3/4"	1 1/4"	16	50	54,5	32	19	18,5	17	161	BIFOV025034E
32 x 1"	1 1/2"	16	58	59,5	38	22	19,5	18	181	BIFOV032100E
40 x 1 1/4"	2"	16	72	68,5	48	26	21,5	21	373	BIFOV040114E
50 x 1 1/2"	2 1/4"	16	79	84,5	55	31	23	24,5	460	BIFOV050112E
63 x 2"	2 3/4"	16	98	94,5	69	38	27	29,5	824	BIFOV063200E

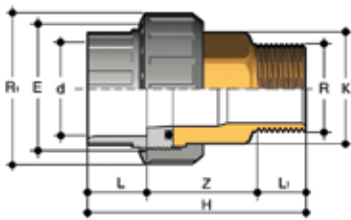

BIROV

Adaptor union in PVC-U/brass with solvent weld socket d and BSP threaded brass male end R with O-Ring in EPDM

d x R	R ₁	PN	E	H	K	L	L ₁	Z	g	Code
16 x 3/8"	3/4"	16	33	58,5	20	14	10,5	34	79	BIROV016038E
20 x 1/2"	1"	16	41	65	25	16	13,5	35,5	131	BIROV020012E
25 x 3/4"	1 1/4"	16	50	72,5	32	19	15	38,5	229	BIROV025034E
32 x 1"	1 1/2"	16	58	80	38	22	17,5	40,5	188	BIROV032100E
40 x 1 1/4"	2"	16	72	91	48	26	19,5	45,5	550	BIROV040114E
50 x 1 1/2"	2 1/4"	16	79	101	55	31	19,5	50,5	681	BIROV050112E
63 x 2"	2 3/4"	16	98	122,5	69	38	24	60,5	1183	BIROV063200E

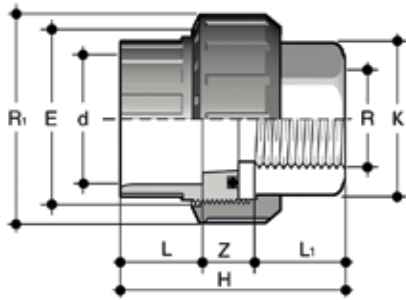

BIFXV

Adaptor union in PVC-U/stainless steel with solvent weld socket d and BSP threaded A316L stainless steel female end R with O-Ring in EPDM or FKM

d x R	R ₁	PN	E	H	K	L	L ₁	Z	g	EPDM code	FKM code
16 x 3/8"	3/4"	16	33	45,5	20	14	13,5	18	50	BIFXV016038E	BIFXV016038F
20 x 1/2"	1"	16	41	48,5	25	16	16,5	16	81	BIFXV020012E	BIFXV020012F
25 x 3/4"	1 1/4"	16	50	54,5	32	19	18,5	17	152	BIFXV025034E	BIFXV025034F
32 x 1"	1 1/2"	16	58	59,5	38	22	19,5	18	170	BIFXV032100E	BIFXV032100F
40 x 1 1/4"	2"	16	72	68,5	48	26	21,5	21	353	BIFXV040114E	BIFXV040114F
50 x 1 1/2"	2 1/4"	16	79	84,5	55	31	23	30,5	435	BIFXV050112E	BIFXV050112F
63 x 2"	2 3/4"	16	98	94,5	69	38	27	29,5	779	BIFXV063200E	BIFXV063200F

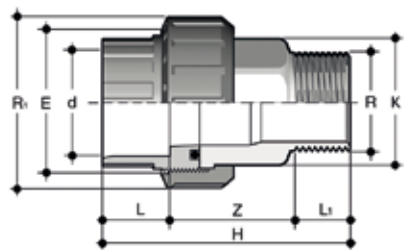

BIRXV

Adaptor union in PVC-U/stainless steel with solvent weld socket d and BSP threaded A316L stainless steel male end R with O-Ring in EPDM or FKM

d x R	R ₁	PN	E	H	K	L	L ₁	Z	g	EPDM code	FKM code
16 x 3/8"	3/4"	16	33	58,5	20	14	10,5	34	74	BIRXV016038E	BIRXV016038F
20 x 1/2"	1"	16	41	65	25	16	13,5	35,5	123	BIRXV020012E	BIRXV020012F
25 x 3/4"	1 1/4"	16	50	72,5	32	19	15	38,5	215	BIRXV025034E	BIRXV025034F
32 x 1"	1 1/2"	16	58	80	38	22	17,5	40,5	269	BIRXV032100E	BIRXV032100F
40 x 1 1/4"	2"	16	72	91	48	26	19,5	45,5	516	BIRXV040114E	BIRXV040114F
50 x 1 1/2"	2 1/4"	16	79	101	55	31	19,5	50,5	639	BIRXV050112E	BIRXV050112F
63 x 2"	2 3/4"	16	98	122,5	69	38	24	60,5	1111	BIRXV063200E	BIRXV063200F

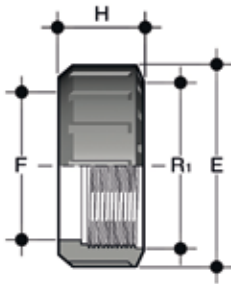

EFV

Union nut with BSP thread for union types BIV, BIFV, BFV, BLV, BIRV, BIFOV, BIROV, BIFXV, BIRXV.

R ₁	d BIV	PN	E	F	H	g	Code
1/2"	-	16	27	17	24	8	EFV012
3/4"	16	16	33	22	21	9	EFV034
1"	20	16	41	28	22	13	EFV100
1 1/4"	25	16	50	36	25	22	EFV114
1 1/2"	32	16	58	42	27	30	EFV112
2"	40	16	72	53	30	50	EFV200
2 1/4"	50	16	79	59	34	68	EFV214
2 1/2"	-	16	90	68	36	95	EFV212
2 3/4"	63	16	98	74	38	120	EFV234
3 1/2"	75	10	120	93	45	198	EFV312
4"	90	10	135	106	52	278	EFV400
5"	110	10	163	129	60	448	EFV500

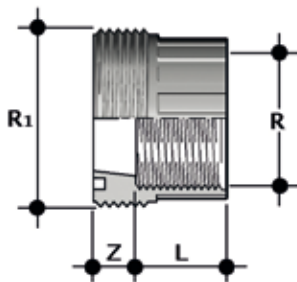

F/BFV

Union bush with BSP threaded female end for union types BIV, BIFV, BFV, BLV, BIRV, BIFOV, BIROV, BIFXV, BIRXV

R	R ₁	PN	L	Z	g	Code
3/8"	3/4"	16	11,4	12,6	8	FBFV038
1/2"	1"	16	15	11	13	FBFV012
3/4"	1 1/4"	16	16,3	12,7	22	FBFV034
1"	1 1/2"	16	19,1	12,9	32	FBFV100
1 1/4"	2"	16	21,4	16,6	57	FBFV114
1 1/2"	2 1/4"	16	21,4	16,5	64	FBFV112
2"	2 3/4"	16	25,7	20,5	122	FBFV200

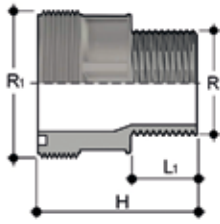

F/BRV

Union bush with BSP threaded male end for union types BIV, BIFV, BFV, BLV, BIRV, BIFOV, BIROV, BIFXV, BIRXV

R	R ₁	PN	L ₁	g	Code
1 1/2	2 1/4	16	22,5	100	FBRV112214
2"	2 1/4	16	27	120	FBRV200214
2"	2 3/4	16	27	175	FBRV200234

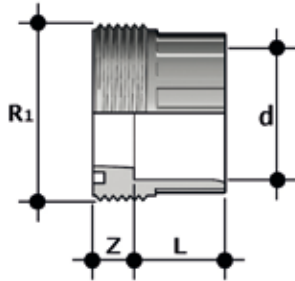

F/BIV

Union bush for solvent welding, metric series for union types BIV, BIFV, BFV, BLV, BIRV, BIFOV, BIROV, BIFXV, BIRXV

d	R ₁	PN	L	Z	g	Code
16	3/4"	16	14	10	9	FBIV016
20	1"	16	16	10	13	FBIV020
25	1 1/4	16	19	10	25	FBIV025
32	1 1/2	16	22	10	31	FBIV032
40	2"	16	26	12	58	FBIV040
50	2 1/4	16	31	14	63	FBIV050
63	2 3/4	16	38	19	119	FBIV063
75	3 1/2	10	44	18	230	FBIV075
90	4"	10	51	18	290	FBIV090
110	5"	10	61	18	500	FBIV110

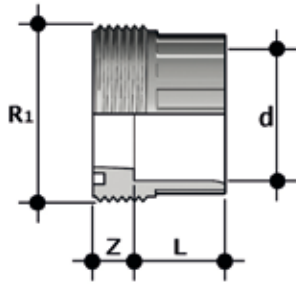

F/BLV

Union bush for solvent welding, series BS for union types BIV, BIFV, BFV, BLV, BIRV, BIFOV, BIROV, BIFXV, BIRXV

d	R ₁	PN	L	Z	g	Code
1/2"	1"	16	16	10	12,5	FBLV012
3/4"	1 1/4"	16	19	10	22,5	FBLV034
1"	1 1/2"	16	22	10	30	FBLV100
1 1/4"	2"	16	26	12	52	FBLV114
1 1/2"	2 1/2"	16	31	14	69,5	FBLV112
2"	2 3/4"	16	38	19	133,5	FBLV200

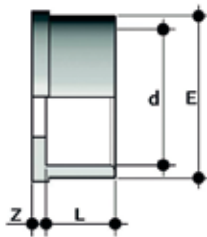

Q/BIV

Union end for solvent welding, metric series for union types BIV, BIFV, BFV, BLV, BIRV, BIFOV, BIROV, BIFXV, BIRXV

d	PN	E	L	Z	g	Code
16	16	22	14	3	5	QBIV016
20	16	28	16	3	8	QBIV020
25	16	36	19	3	15	QBIV025
32	16	42	22	3	24	QBIV032
40	16	53	26	3	37	QBIV040
50	16	59	31	3	42	QBIV050
63	16	74	38	3	77	QBIV063
75	10	93	44	3	150	QBIV075
90	10	105	51	5	192	QBIV090
110	10	129	61	5	335	QBIV110

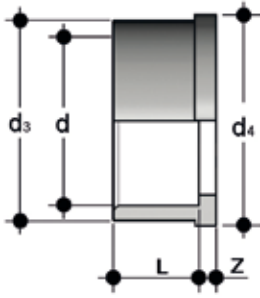

Q/BLV

Union end for solvent welding, BS series for union types BIV, BIFV, BFV, BLV, BIRV, BIFOV, BIROV, BIFXV, BIRXV

d	PN	d ₃	d ₄	L	Z	g	Code
1/2"	16	27,5	30,1	16	3	8	QBLV012
3/4"	16	36	38,8	19	3	13	QBLV034
1"	16	41,5	44,7	22	3	19	QBLV100
1 1/4"	16	53	56,5	26	3	32	QBLV114
1 1/2"	16	59	62,6	31	3	46	QBLV112
2"	16	74	78,4	38	3	86	QBLV200

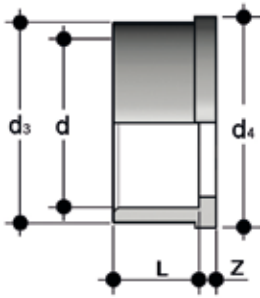

Q/BAV

Union end for solvent welding, ASTM series for union types BIV, BIFV, BFV, BLV, BIRV, BIFOV, BIROV, BIFXV, BIRXV

d	PN	d ₃	d ₄	L	Z	g	Code
1/2"	16	27,5	30,1	22,7	3,5	15,5	QBAV012
3/4"	16	36	38,8	25,9	3,7	22,5	QBAV034
1"	16	41,5	44,7	29,2	3	32,5	QBAV100
1 1/4"	16	53	56,5	32	5	57	QBAV114
1 1/2"	16	59	62,6	35	5	78	QBAV112
2"	16	74	78,4	38,5	5,5	130	QBAV200

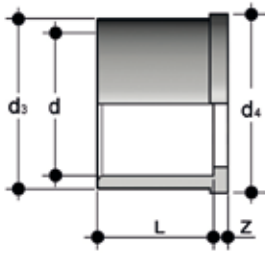

Q/BJV

Union end for solvent welding, JIS series for union types BIV, BIFV, BFV, BLV, BIRV, BIFOV, BIROV, BIFXV, BIRXV

d	PN	d ₃	d ₄	L	Z	g	Code
1/2"	16	27,5	30,1	30	3	16	QBJV012
3/4"	16	36	38,8	35	3,5	21	QBJV034
1"	16	41,5	44,7	40	3	40	QBJV100
1"1/4	16	53	56,5	44	3	68	QBJV114
1"1/2	16	59	62,6	55	4,5	105	QBJV112
2"	16	74	78,4	62,9	5,5	175	QBJV200

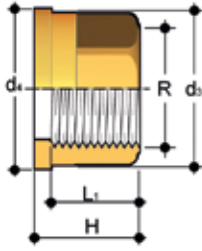

Q/BFO

Union end in brass with female BSP thread for union types BIV, BIFV, BFV, BLV, BIRV, BIFOV, BIROV, BIFXV, BIRXV

R	d ₁	d ₂	H	L ₁	g	Code
3/8"	22	24	21,5	13,5	38	QBFO038
1/2"	27,5	30,1	22,5	16,5	60	QBFO012
3/4"	36	38,8	25,5	18,5	116	QBFO034
1"	41,5	44,7	27,5	19,5	144	QBFO100
1 1/4"	53	56,5	30,5	21,5	260	QBFO114
1 1/2"	59	62,6	33,5	23	325	QBFO112
2"	74	78,4	38,5	27	578	QBFO200

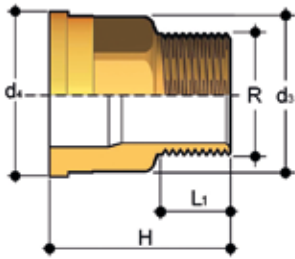

Q/BRO

Union end in brass with male BSP thread for union types BIV, BIFV, BFV, BLV, BIRV, BIFOV, BIROV, BIFXV, BIRXV

R	d ₁	d ₂	H	L ₁	g	Code
3/8"	22	24	34,5	10,5	64	QBRO038
1/2"	27,5	30,1	39	13,5	105	QBRO012
3/4"	36	38,8	43,5	15	184	QBRO034
1"	41,5	44,7	48	17,5	251	QBRO100
1 1/4"	53	56,5	53	19,5	437	QBRO114
1 1/2"	59	62,6	56	19,5	545	QBRO112
2"	74	78,4	65,5	24	937	QBRO200

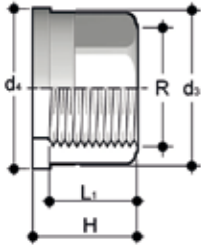

Q/BFX

Union end in A316L stainless steel with female BSP thread for union types BIV, BIFV, BFV, BLV, BIRV, BIFOV, BIROV, BIFXV, BIRXV

R	d ₂	d ₃	H	L ₁	g	Code
3/8"	22	24	21,5	13,5	34	QBFX038
1/2"	27,5	30,1	22,5	16,5	54	QBFX012
3/4"	36	38,8	25,5	18,5	104	QBFX034
1"	41,5	44,7	27,5	19,5	130	QBFX100
1 1/4"	53	56,5	30,5	21,5	234	QBFX114
1 1/2"	59	62,6	33,5	23	293	QBFX112
2"	74	78,4	38,5	27	520	QBFX200

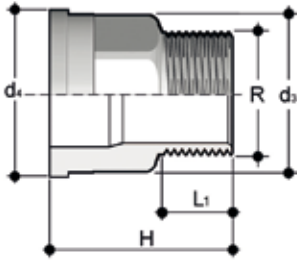

Q/BRX

Union end in A316L stainless steel with male BSP thread for union types BIV, BIFV, BFV, BLV, BIRV, BIFOV, BIROV, BIFXV, BIRXV

R	d ₂	d ₃	H	L ₁	g	Code
3/8"	22	24	34,5	10,5	58	QBRX038
1/2"	27,5	30,1	39	13,5	95	QBRX012
3/4"	36	38,8	43,5	15	166	QBRX034
1"	41,5	44,7	48	17,5	226	QBRX100
1 1/4"	53	56,5	53	19,5	393	QBRX114
1 1/2"	59	62,6	56	19,5	491	QBRX112
2"	74	78,4	65,5	24	843	QBRX200

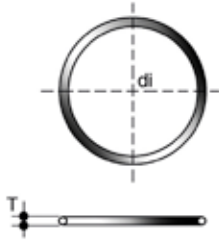

O-RING

O-Ring for union types BIV, BIFV, BFV, BLV, BIRV, BIFOV, BIROV, BIFXV, BIRXV

Union d	C	di	T	d	EPDM code	FKM code
16	3062	15,54	2,62	16	OR3062E	OR3062F
20	4081	20,22	3,53	20	OR4081E	OR4081F
25	4112	28,17	3,53	25	OR4112E	OR4112F
32	4131	32,93	3,53	32	OR4131E	OR4131F
40	6162	40,65	5,34	40	OR6162E	OR6162F
50	6187	47	5,34	50	OR6187E	OR6187F
63	6237	59,69	5,34	63	OR6237E	OR6237F
75	6300	75,57	5,34	75	OR6300E	OR6300F
90	6362	91,45	5,34	90	OR6362E	OR0185F
110	6450	113,67	5,34	110	OR6450E	OR6450F

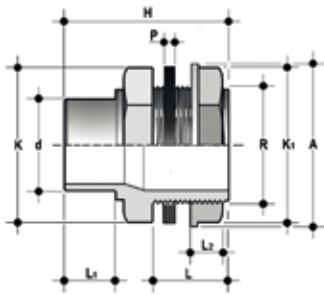

LIV

Tank connector with solvent weld spigot d, threaded joint R with tightening nut and flat gasket in EPDM

d x R	PN	A	H	K	K ₁	L	L ₁	L ₂	L ₃	P	g	Code
25 x 1"	16	58	60	46	46	26	19	16		2	58	LIV025100
32 x 1 1/4"	16	62	66	55	50	28	22	18		2	90	LIV032114

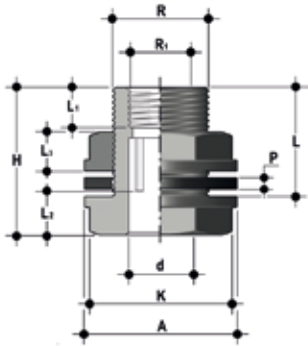

LIFV

Tank connector with solvent weld socket d, male threaded joint R and female threaded joint R1 with tightening nut and flat gasket in EPDM or FKM

d x R x R ₁	PN	A	H	K	L	L ₁	L ₂	L ₃	P	g	EPDM code	FKM code
16 x 3/4" x 1/2"	16	44	60,5	33	47	15	14	13,5	3	53	1RAS316B00	1RAS316B10
20 x 1" x 3/4"	16	58	65	46	49	16,3	16	16	3	108	1RAS320C00	1RAS320C10
25 x 1 1/4 x 1"	16	62	70	50	52	19,1	19	18	3	142	1RAS325D00	1RAS325D10
32 x 1 1/2 x 1"	16	76	73	60	54	19,1	22	19	3	192	1RAS332D00	1RAS332D10
40 x 2" x 1 1/2"	16	92	81	79	60	21,4	26	20,8	3	337	1RAS340F00	1RAS340F10

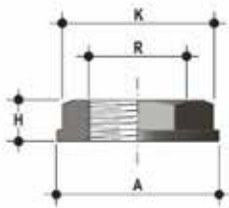

JFV

Back nut with BSP thread (used on LIV and LIFV)

R	PN	A	H	K	g	Code
1/2"	16	38	13	28	11	1RNU220000
3/4"	16	44	13,5	33	14	1RNU225000
1"	16	58	16	46	31	1RNU232000
1 1/4"	16	62	18	50	32	1RNU240000
1 1/2"	16	76	19	60	52	1RNU250000
2"	16	92	21	79	84	1RNU263000



BSP FITTINGS

PVC-U

Threaded fittings



BSP FITTINGS

Series of fittings for pipes conveying fluids under pressure with threaded joints.

THREADED FITTINGS

Technical specifications	
Size range	R 3/8" ÷ 4"
Nominal pressure	PN 16 with water at 20 °C
Temperature range	0 °C ÷ 60 °C
Coupling standards	Thread: ISO 228-1, DIN 2999, ISO 7, BS 21, ASTM D 2464, JIS B0203 Flanging system: DIN 2501, EN 1092-1
Reference standards	Construction criteria: EN ISO 1452, EN 15493 Test methods and requirements: EN ISO 1452, EN ISO 15493
Fittings material	PVC-U Grey RAL 7011
Seal material	EPDM, FKM

TECHNICAL DATA

PRESSURE VARIATION ACCORDING TO TEMPERATURE

For water and non-hazardous fluids for which the material is classified as CHEMICALLY RESISTANT (life expectancy 25 years). In other cases, a reduction of the nominal pressure PN is required.

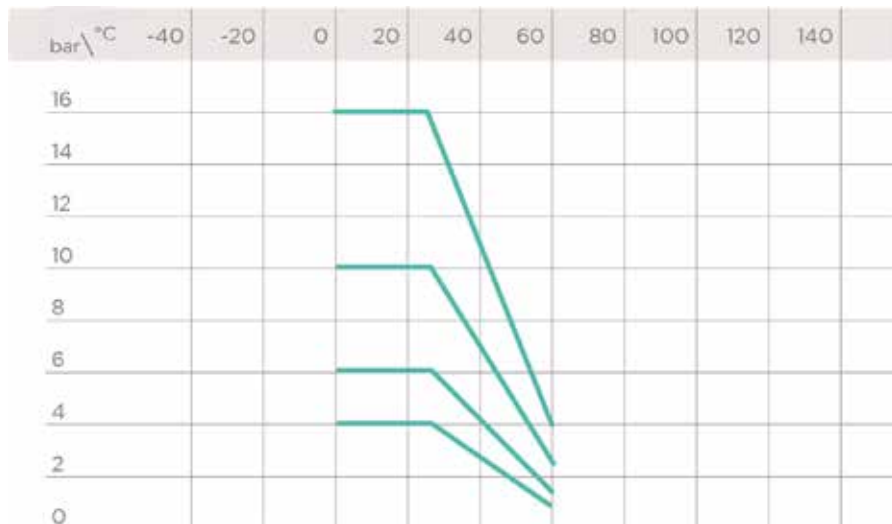

REGRESSION CURVE FOR PVC-U FITTINGS

Regression coefficients according to EN ISO 1452 and EN ISO 15493 for MRS (minimum required strength) values = 25 N/mm² (MPa) (classification PVC-U 250)

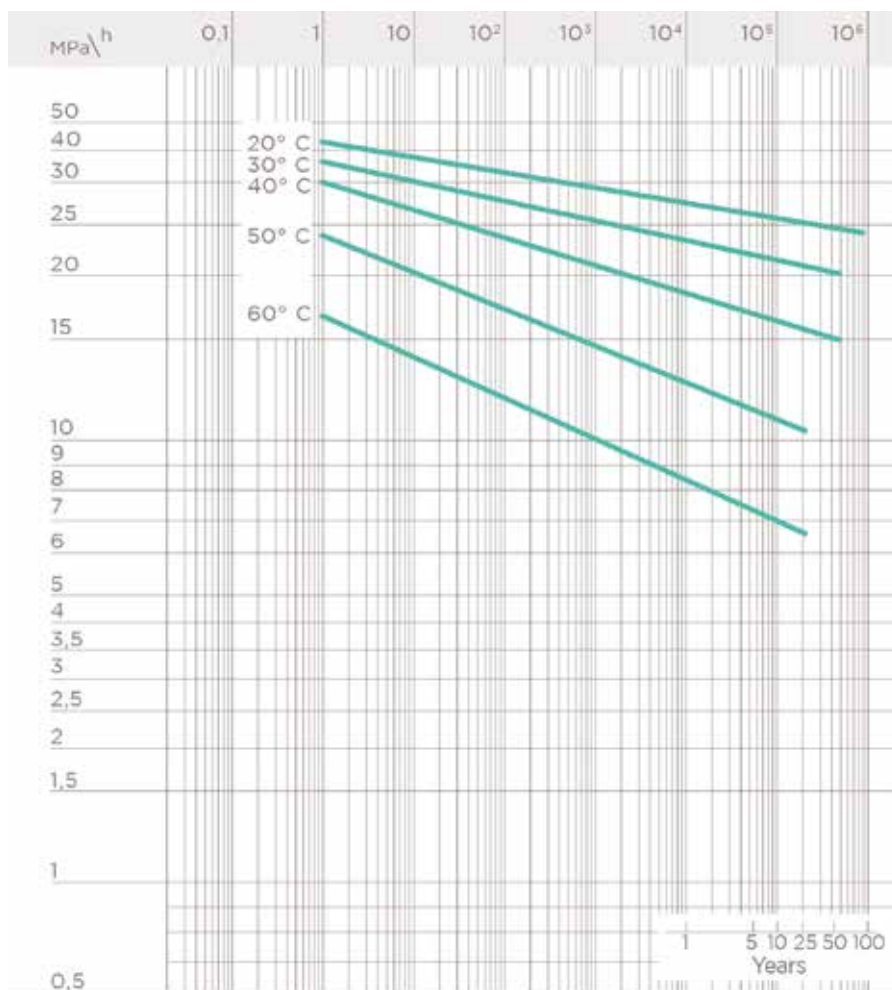

SAFETY FACTORS

The table reports the safety factors for each pressure class as a function of time.

Nominal pressure PN must be understood as being the standard pressure used for calculating and selecting the required fittings. In order to be able to comply with the safety factors, the maximum continuous working pressure at 20° C when conveying water must be the same as the nominal pressure values. Unless otherwise specified, the nominal pressures are as follows:

- solvent weld fittings from d 12 to d 225 PN 16 from d 250 to d 315 PN 10
- adaptor fittings from d 16 to d 110 PN 16
- threaded fittings from R 3/8" to R 4" up to PN 16.

Pe (bar)	1h	1000h	50 years	T
10	6,72	5,12	4	
16	4,2	3,2	2,5	

DIMENSIONS

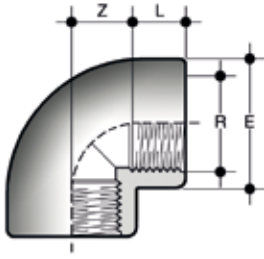

GFV

90° elbow with BSP threaded female ends

R	PN	E	L	Z	g	Code
3/8"	16	23,5	11,4	13	16	GFV038
1/2"	16	28,5	15	13	24	GFV012
3/4"	16	35	16,3	17	40	GFV034
1"	16	43	19,1	21	72	GFV100
1 1/4"	16	54	21,4	27	130	GFV114
1 1/2"	16	61	21,4	36	185	GFV112
2"	16	76	25,7	46	350	GFV200
2 1/2"	16	91	30,2	55	450	GFV212
3"	16	108	33,3	66	835	GFV300
4"	16	130	39,3	80	1135	GFV400

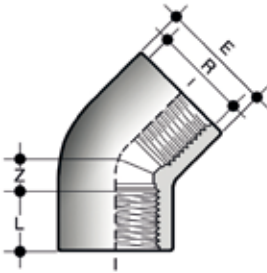

HFV

45° elbow with BSP threaded female ends

R	PN	E	L	Z	g	Code
1/2"	16	28	15	6,5	18	HFV012
3/4"	16	33	16,3	8	24	HFV034
1"	16	41	19,1	10,5	45	HFV100
1 1/4"	16	50	21,4	15	68	HFV114
1 1/2"	16	64	21,4	21	154	HFV112
2"	16	76	25,7	26	255	HFV200
2 1/2"	16	90	30,2	31	345	HFV212
3"	16	107	33,3	39	625	HFV300

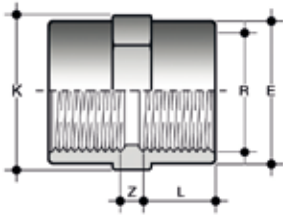

MFV

Double socket with BSP threaded female ends

R	PN	E	K	L	Z	g	Code
3/8"	16	23,5	24	11,4	8	10	MFV038
1/2"	16	28,5	29	15	7	17	MFV012
3/4"	16	35	35	16,3	8,5	26	MFV034
1"	16	43	43	19,1	9	42	MFV100
1 1/4"	16	50	50	21,4	11	53	MFV114
1 1/2"	16	61	61	21,4	17,5	108	MFV112
2"	16	76	76	25,7	19,5	190	MFV200
2 1/2"	16	90	90	30,2	31	275	MFV212
3"	16	108	108	33,3	40,5	500	MFV300
4"	16	131	131	39,3	48,5	665	MFV400

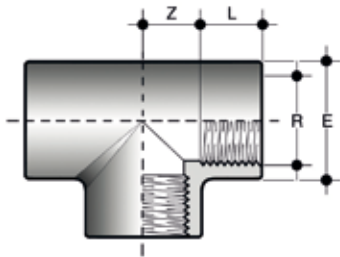

TFV

90° Tee with BSP threaded female ends

R	PN	E	L	Z	g	Code
3/8"	16	23,5	11,4	13	20	TFV038
1/2"	16	28,5	15	13	32	TFV012
3/4"	16	35	16,3	17	52	TFV034
1"	16	43	19,1	21,5	92	TFV100
1 1/4"	16	50	21,4	27	117	TFV114
1 1/2"	16	61	21,4	37	260	TFV112
2"	16	76	25,7	46	465	TFV200
2 1/2"	16	91	30,2	55	640	TFV212
3"	16	109	33,3	66	1135	TFV300
4"	16	133	39,3	83	1710	TFV400

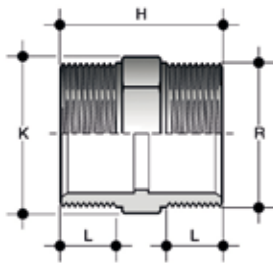

NFV

Barrel nipple with BSP threaded male ends

R	PN	E	H	K	L	g	Code
3/8"	16	22	33	19	11,4	5	NFV038
1/2"	16	28	42	24	15	10	NFV012
3/4"	16	34	44	30	16,3	20	NFV034
1"	16	40	50	36	19,1	30	NFV100
1 ¹ / ₄ "	16	52	58	46	21,4	45	NFV114
1 ¹ / ₂ "	16	58	58	50	21,4	63	NFV112
2"	16	70	66	65	25,7	105	NFV200
*2 ¹ / ₂ "	16	-	78	80	30,2	175	NFV212
*3"	16	-	85	95	33,3	245	NFV300
*4"	16	-	90	120	39,3	348	NFV400

* Reduced safety factor

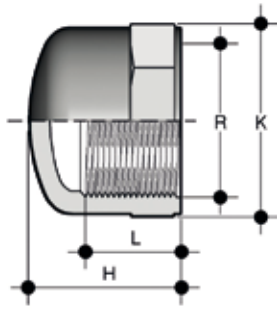

CFV

End cap with BSP female thread

R	PN	H	K	L	g	Code
3/8"	16	19	23	11,4	6	1RCA216000
1/2"	16	25	28	15	10	CFV012
3/4"	16	27	34	16,3	15	CFV034
1"	16	31	42	19,1	27	CFV100
1 1/4"	16	35	51	21,4	40	CFV114
1 1/2"	16	36	58	21,4	53	CFV112
2"	16	42	71	25,7	85	CFV200
3"	16	55	109	33,3	310	CFV300

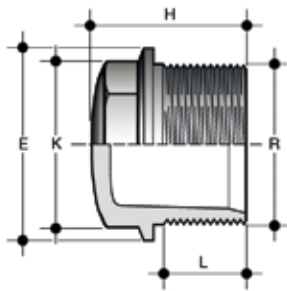

Fig. A Plug with BSP male thread (Fig. A)

PFV

R	PN	E	H	K	L	g	Code
3/8"	16	22	22	18	11,4	4	PFV038
1/2"	16	28	26	23	15	8	PFV012
3/4"	16	34	30	28	16,3	11	PFV034
1"	16	40	34	35	19,1	21	PFV100
1 1/4"	16	52	38	44	21,4	30	PFV114
1 1/2"	16	58	40	51	21,4	46	PFV112
2"	16	70	47	64	25,7	74	PFV200

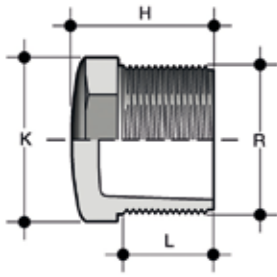
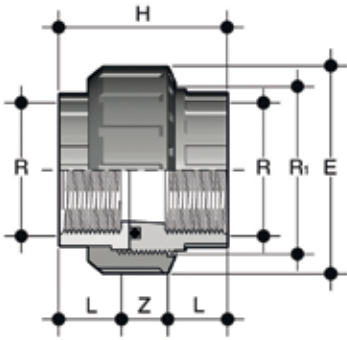

Fig. B **PFV** Plug with BSP male thread (Fig. B)

R	PN	E	H	K	L	g	Code
2 1/2"	16	-	61	80	30,2	180	PFV212
3"	16	-	71	93	33,3	245	PFV300
4"	16	-	87	118	39,3	550	PFV400



BFV

Union with BSP threaded female ends, O-Ring in EPDM or FKM

R	R ₁	PN	E	H	L	Z	g	Code
3/8"	3/4"	16	33	40	11.4	17.2	22	BFV038E
1/2"	1"	16	41	46	15	16	35	BFV012E
3/4"	1 1/4"	16	50	51	16.3	18.4	65	BFV034E
1"	1 1/2"	16	58	57	19,10	18.8	85	BFV100E
1 1/4"	2"	16	72	65	21.4	22.2	145	BFV114E
1 1/2"	2 1/4"	16	79	65	21.4	22.2	180	BFV112E
2"	2 3/4"	16	98	78	25.7	26.6	325	BFV200E

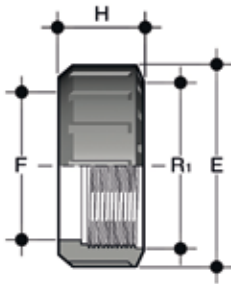

EFV

Union nut with BSP thread for union types BIV, BIFV, BFV, BLV, BIRV, BIFOV, BIROV, BIFXV, BIRXV

R ₁	d BIV	PN	E	F	H	g	Code
1/2"	-	16	27	17	24	8	EFV012
3/4"	16	16	33	22	21	9	EFV034
1"	20	16	41	28	22	13	EFV100
1 1/4"	25	16	50	36	25	22	EFV114
1 1/2"	32	16	58	42	27	30	EFV112
2"	40	16	72	53	30	50	EFV200
2 1/4"	50	16	79	59	34	68	EFV214
2 1/2"	-	16	90	68	36	95	EFV212
2 3/4"	63	16	98	74	38	120	EFV234
3 1/2"	75	10	120	93	45	198	EFV312
4"	90	10	135	106	52	278	EFV400
5"	110	10	163	129	60	448	EFV500

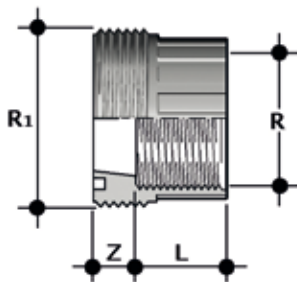

F/BFV

Union bush with BSP threaded female end for union types BIV, BIFV, BFV, BLV, BIRV, BIFOV, BIROV, BIFXV, BIRXV

R	R ₁	PN	L	Z	g	Code
3/8"	3/4"	16	11,4	12,6	8	FBFV038
1/2"	1"	16	15	11	13	FBFV012
3/4"	1 1/4"	16	16,3	12,7	22	FBFV034
1"	1 1/2"	16	19,1	12,9	32	FBFV100
1 1/4"	2"	16	21,4	16,6	57	FBFV114
1 1/2"	2 1/4"	16	21,4	16,5	64	FBFV112
2"	2 3/4"	16	25,7	20,5	122	FBFV200

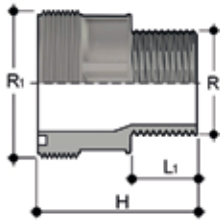

F/BRV

Union bush with BSP threaded male end for union types BIV, BIFV, BFV, BLV, BIRV, BIFOV, BIROV, BIFXV, BIRXV

R	R ₁	PN	L ₁	g	Code
1 1/2"	2 1/4"	16	22,5	100	FBRV112214
2"	2 1/4"	16	27	120	FBRV200214
2"	2 3/4"	16	27	175	FBRV200234

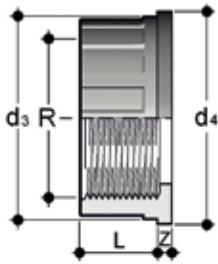

Q/BFV

Union end with BSP female thread for union types BIV, BIFV, BFV, BLV, BIRV, BIFOV, BIROV, BIFXV, BIRXV

R	PN	d ₃	d ₄	L	Z	g	Code
3/8"	16	22	24	11,4	4,5	4,5	QBFV038
1/2"	16	27,5	30,1	15	5	8,5	QBFV012
3/4"	16	36	38,8	16,3	5	15,5	QBFV034
1"	16	41,5	44,7	19,1	5,5	21,0	QBFV100
1 1/4"	16	53	56,5	21,4	5,5	33,5	QBFV114
1 1/2"	16	59	62,6	21,4	5,5	40,0	QBFV112
2"	16	74	78,4	25,7	5,5	72,0	QBFV200

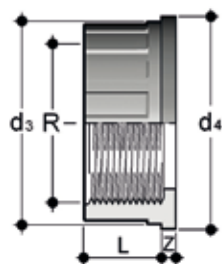

Q/BNV

Union end with NPT female thread for union types BIV, BIFV, BFV, BLV, BIRV, BIFOV, BIROV, BIFXV, BIRXV

R	PN	d_3	d_4	L	Z	g	Code
3/8"	16	22	24	12,7	6,3	10	QBNV038
1/2"	16	27,5	30,1	17,8	5,2	15	QBNV012
3/4"	16	36	38,8	18	5,2	20	QBNV034
1"	16	41,5	44,7	22,6	5,7	30	QBNV100
1 1/4"	16	53	56,5	25,1	7,3	55	QBNV114
1 1/2"	16	59	62,6	24,7	7	70	QBNV112
2"	16	74	78,4	29,6	7,8	115	QBNV200

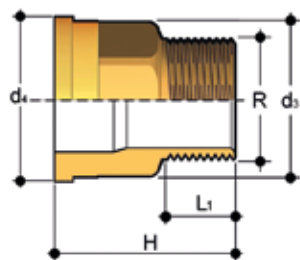

Q/BRO

Union end in brass with male BSP thread for union types BIV, BIFV, BFV, BLV, BIRV, BIFOV, BIROV, BIFXV, BIRXV

R	d_3	d_4	H	L_1	g	Code
3/8"	22	24	34,5	10,5	64	QBRO038
1/2"	27,5	30,1	39	13,5	105	QBRO012
3/4"	36	38,8	43,5	15	184	QBRO034
1"	41,5	44,7	48	17,5	251	QBRO100
1 1/4"	53	56,5	53	19,5	437	QBRO114
1 1/2"	59	62,6	56	19,5	545	QBRO112
2"	74	78,4	65,5	24	937	QBRO200

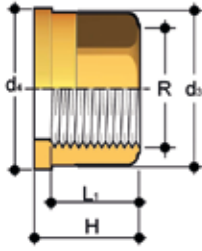

Q/BFO

Union end in brass with female BSP thread for union types BIV, BIFV, BFV, BLV, BIRV, BIFOV, BIROV, BIFXV, BIRXV

R	d ₂	d ₃	H	L ₁	g	Code
3/8"	22	24	21,5	13,5	38	QBFO038
1/2"	27,5	30,1	22,5	16,5	60	QBFO012
3/4"	36	38,8	25,5	18,5	116	QBFO034
1"	41,5	44,7	27,5	19,5	144	QBFO100
1 1/4"	53	56,5	30,5	21,5	260	QBFO114
1 1/2"	59	62,6	33,5	23	325	QBFO112
2"	74	78,4	38,5	27	578	QBFO200

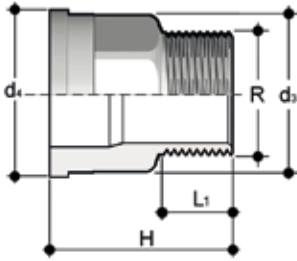

Q/BRX

Union end in A316L stainless steel with male BSP thread for union types BIV, BIFV, BFV, BLV, BIRV, BIFOV, BIROV, BIFXV, BIRXV

R	d ₂	d ₃	H	L ₁	g	Code
3/8"	22	24	34,5	10,5	58	QBRX038
1/2"	27,5	30,1	39	13,5	95	QBRX012
3/4"	36	38,8	43,5	15	166	QBRX034
1"	41,5	44,7	48	17,5	226	QBRX100
1 1/4"	53	56,5	53	19,5	393	QBRX114
1 1/2"	59	62,6	56	19,5	491	QBRX112
2"	74	78,4	65,5	24	843	QBRX200

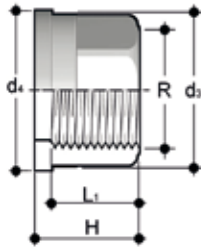

Q/BFX

Union end in A316L stainless steel with female BSP thread for union types BIV, BIFV, BFV, BLV, BIRV, BIFOV, BIROV, BIFXV, BIRXV

R	d ₂	d ₁	H	L ₁	g	Code
3/8"	22	24	21,5	13,5	34	QBFX038
1/2"	27,5	30,1	22,5	16,5	54	QBFX012
3/4"	36	38,8	25,5	18,5	104	QBFX034
1"	41,5	44,7	27,5	19,5	130	QBFX100
1 1/4"	53	56,5	30,5	21,5	234	QBFX114
1 1/2"	59	62,6	33,5	23	293	QBFX112
2"	74	78,4	38,5	27	520	QBFX200

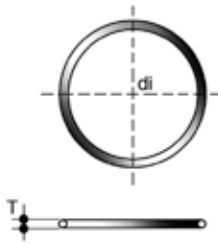

O-RING

O-ring for union types BIV, BIFV, BFV, BLV, BIRV, BIFOV, BIROV, BIFXV, BIRXV

Union D	C	di	T	EPDMCode	FKM code
16	3062	15,54	2,62	OR3062E	OR3062F
20	4081	20,22	3,53	OR4081E	OR4081F
25	4112	28,17	3,53	OR4112E	OR4112F
32	4131	32,93	3,53	OR4131E	OR4131F
40	6162	40,65	5,34	OR6162E	OR6162F
50	6187	47	5,34	OR6187E	OR6187F
63	6237	59,69	5,34	OR6237E	OR6237F
75	6300	75,57	5,34	OR6300E	OR6300F
90	6362	91,45	5,34	OR6362E	OR6362F
110	6450	113,67	5,34	OR6450E	OR6450F

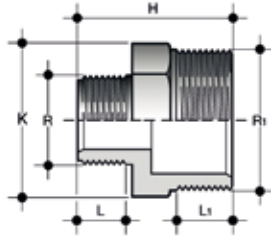

NRFV

Reducing barrel nipple with BSP threaded male ends

R ₁ x R	PN	H	K	L	L ₁	g	Code
3/4" x 1/2"	16	43	30	15	16,3	15	NRFV034012
1" x 3/4"	16	47	36	16,3	19,1	25	NRFV100034
1"1/4 x 1"	16	54	46	19,1	21,4	40	NRFV114100
1"1/2 x 1"1/4	16	60	50	21,4	21,4	60	NRFV112114
2" x 1"1/2	16	62	65	21,4	25,7	90	NRFV200112
2"1/2 x 2"	16	72	80	25,7	30,2	155	NRFV212200
3" x 2"1/2	16	82	95	30,2	33,3	240	NRFV300212
4" x 3"	16	91	120	33,3	39,3	357	NRFV400300

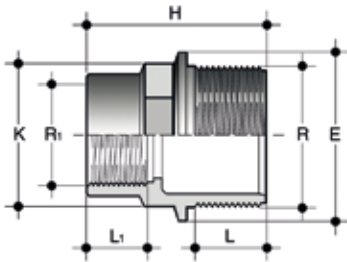

RFV

Fig. A Reducer with BSP threaded male end (R) and BSP threaded female end (R1 reduced) (fig. A)

R x R ₁	PN	E	H	K	L	L ₁	g	Code
1/2" x 3/8"	16	28	35	23	15	11,4	10	RFV012038
3/4" x 3/8"	16	34	36	28	16,3	11,4	12	RFV034038
3/4" x 1/2"	16	34	39	28	16,3	15	15	RFV034012
1" x 3/8"	16	40	41	35	19,1	11,4	20	RFV100038
1" x 1/2"	16	40	44	35	19,1	15	24	RFV100012
1" x 3/4"	16	40	46	35	19,1	16,3	25	RFV100034
1"1/4 x 1/2"	16	52	48	44	21,4	15	37	RFV114012
1"1/4 x 3/4"	16	52	49	44	21,4	16,3	37	RFV114034
1"1/4 x 1"	16	52	52	44	21,4	19,1	40	RFV114100
1"1/2 x 1/2"	16	58	52	51	21,4	15	46	RFV112012
1"1/2 x 3/4"	16	58	50	51	21,4	16,3	47	RFV112034
1"1/2 x 1"	16	58	55	51	21,4	19,1	52	RFV112100
1"1/2 x 1"1/4	16	58	57	51	21,4	21,4	54	RFV112114
2" x 3/4"	16	70	60	64	25,7	16,3	80	RFV200034
2" x 1"	16	70	63	64	25,7	19,1	80	RFV200100
2" x 1"1/4	16	70	65	64	25,7	21,4	85	RFV200114
2" x 1"1/2	16	70	65	64	25,7	21,4	102	RFV200112

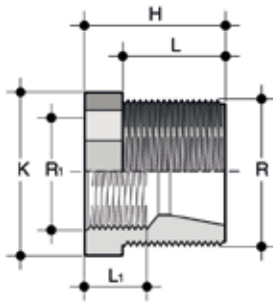

RFV
Fig. B Reducer with BSP threaded male end (R) and BSP threaded female end (R1 reduced) (fig. B)

R x R ₁	PN	E	H	K	L	L ₁	g	Code
2"1/2 x 2"	16	-	56	80	30,2	25,7	155	RFV212200
3" x 2"	16	-	66	93	33,3	25,7	185	RFV300200
3" x 2"1/2	16	-	66	93	33,3	30,2	200	RFV300212
4" x 3"	16	-	79	118	39,3	33,3	500	RFV400300

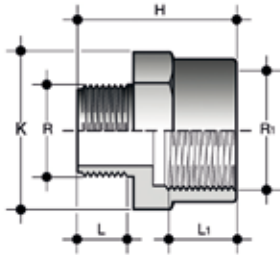

IFFV
 Reducer: BSP threaded female end (R1), BSP threaded male end (R reduced)

R ₁ x R	PN	H	K	L	L ₁	g	Code
3/4" x 1/2"	16	41	36	15	16,3	22	IFFV034012
1" x 1/2"	16	40,5	43	15	19,1	30	IFFV100012
1" x 3/4"	16	42	43	16,3	19,1	42	IFFV100034
1"1/4 x 1"	16	55	55	19,1	21,4	55	IFFV114100
1"1/2 x 1"1/4	16	62	65	21,4	21,4	102	IFFV112114
2" x 1"1/2	16	69	80	21,4	25,7	165	IFFV200112
2"1/2 x 2"	16	81	95	25,7	30,2	210	IFFV212200
3" x 2"1/2	16	93	110	30,2	33,3	360	IFFV300212
4" x 3"	16	106	130	33,3	39,3	500	IFFV400300

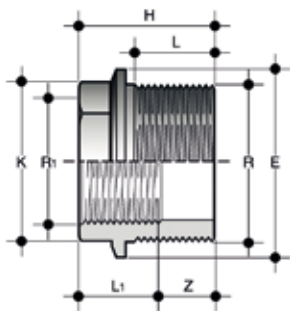

DFV

Reducing bush with BSP threaded male end (R) and BSP threaded female end (R1 reduced)

R x R ₁	PN	E	H	K	L	L ₁	Z	g	Code
1/2" x 3/8"	16	28	24	23	11,4	15	12,6	7	DFV012038
3/4" x 1/2"	16	34	26,5	28	15	16,3	11,5	9	DFV034012
1" x 3/4"	16	40	30,5	35	16,3	19,10	14,2	17	DFV100034
1 1/4 x 1"	16	52	34	44	19,1	21,4	14,9	30	DFV114100
1 1/2 x 1 1/4	16	58	35	51	21,4	21,4	13,6	30	DFV112114
2" x 1 1/2	16	70	40	64	21,4	25,7	18,6	72	DFV200112

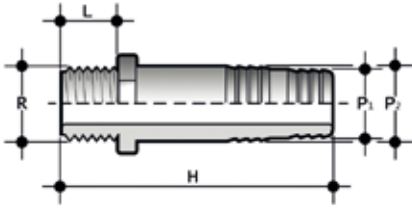

AFV

Hose adaptor with BSP threaded male end

R x P ₁ x P ₂	PN	H	L	g	Code
1/4" x 12 x 14	16	56	11	7	AFV014012014
3/8" x 16 x 18	16	58	11,4	14	AFV038016018
1/2" x 20 x 22	16	66	15	19	AFV012020022
3/4" x 25 x 27	16	81	16,3	30	AFV034025027
1" x 30 x 32	16	97	19,1	45	AFV100030032
1 1/4" x 40 x 42	16	104	21,4	85	AFV114040042
1 1/2" x 50 x 52	16	111	21,4	120	AFV112050052
2" x 60 x 64	16	123	25,7	180	AFV200060064

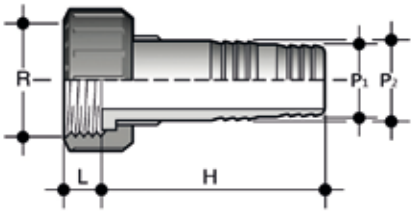

ADV

Hose adaptor with BSP threaded female end (R) and EPDM flat gasket

R x P ₁ x P ₂	PN	H	L	g	Code
1/2" x 12 x 14	16	56	14	15	ADV012012014
3/4" x 16 x 18	16	60	11,5	24	ADV034016018
1" x 20 x 22	16	67	11	35	ADV100020022
1 1/4" x 25 x 27	16	81	14	55	ADV114025027
1 1/2" x 30 x 32	16	97	16	80	ADV112030032
2" x 40 x 42	16	104	18	140	ADV200040042
2" x 50 x 52	16	111	16	180	ADV200050052
2 1/4" x 50 x 52	16	111	17,5	200	ADV214050052
2 3/4" x 60 x 64	16	123	20	300	ADV234060064



BS FITTINGS

PVC-U

Fittings according to british standard



BS FITTINGS

Series of fittings for pipes conveying fluids under pressure with solvent weld and threaded joints according to British Standard.

FITTINGS ACCORDING TO BRITISH STANDARD

Technical specifications	
Size range	d 1/2" ÷ 8"
Nominal pressure	up to 15 bar with water at 20 °C
Temperature range	0 °C ÷ 60 °C
Coupling standards	<p>Solvent welding: BS 4346-1, ASTM D 2467, JIS K 6743, ISO 727, EN ISO 15493, DIN 8063, EN ISO 1452 Can be coupled to pipes according to ISO 7, ASTM D 2464, JIS B 0203</p> <p>Thread: ISO 7, DIN 2999, EN ISO 1452, EN ISO 15493, DIN 8062, ASTM D 1785, JIS K6741, BS 21</p> <p>Flanging system: BS 10 Tab. E</p>
Reference standards	<p>Construction criteria: ISO 7, ASTM D 2464, JIS B 0203, EN ISO 1452, EN ISO 15493</p> <p>Test methods and requirements: BS 4346-1</p> <p>Installation criteria: DVS 2204, DVS 2221, UNI 11242</p>
Fittings material	PVC-U Grey RAL 7011
Seal material	EPDM

TECHNICAL DATA

PRESSURE VARIATION ACCORDING TO TEMPERATURE

For water and non-hazardous fluids with regard to which the material is classified as CHEMICALLY RESISTANT. In other cases, a reduction of the nominal pressure PN is required (25 years with safety factor).

class E 15 bar
class D 12 bar
class C 9 bar

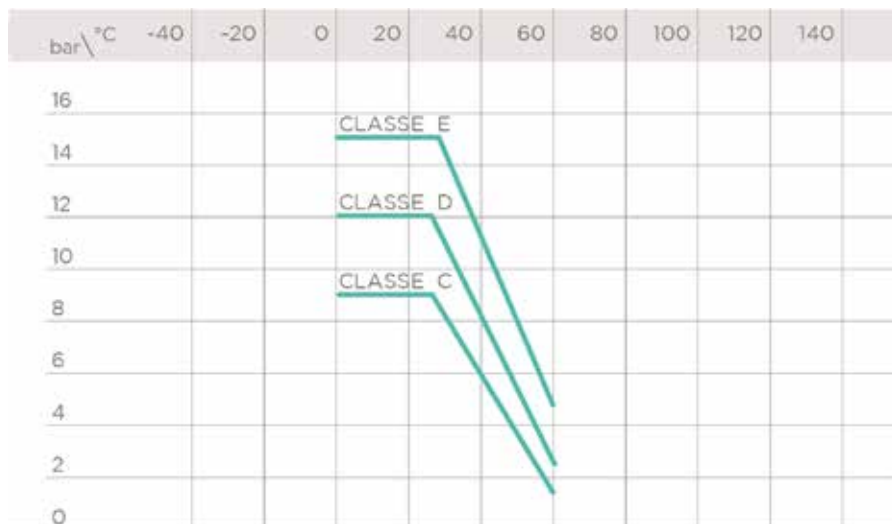

SAFETY FACTORS

The table reports the safety factors for each pressure class as a function of time.

BS fittings are split into pressure classes according to usage. In order to be able to comply with the safety factors, the maximum continuous working pressure at 20° C when conveying water must be the same as the pressure class. Unless otherwise specified, the nominal pressures are as follows:

- solvent weld fittings from d 1/2" to d 4" class E from d 6" to d 8" class D
- adaptor fittings from d 1/2" to d 2" class E from d 2 1/2" to d 4" class D

Class	Pe (bar)	1h	50 years	T
E	15	3,6	2,10	
D	12	4,50	2,60	
C	9	6	3,50	

DIMENSIONS

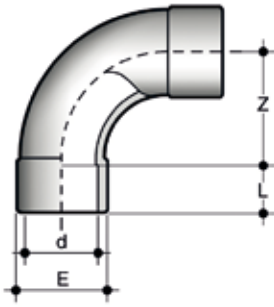

SLV

90° long radius bend (R=2D) with solvent weld sockets

d	PN	E	L	Z	g	Class	Code
1/2"	15	28	16	40	45	E	1RCU420000
3/4"	15	34	19	50	75	E	1RCU425000
1"	15	41	22	64	120	E	1RCU432000
1 1/4"	15	51	26	80	205	E	1RCU440000
1 1/2"	15	65	31	100	310	E	1RCU450000
2"	15	77	38	126	510	E	1RCU463000
2 1/2"	15	94	44	150	1000	E	SIV075

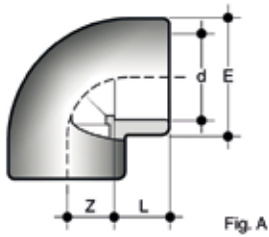
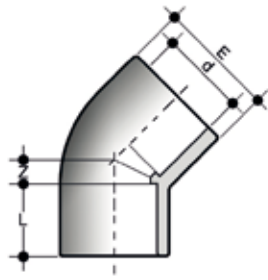

Fig. A

GLV

90° elbow with solvent weld sockets

d	PN	E	L	Z	g	Class	Code
1/2"	15	27	16,5	10,5	15	E	GLV012
3/4"	15	33	19,5	13,5	30	E	GLV034
1"	15	41	22,5	17	45	E	GLV100
1 1/4"	15	54	27	21,5	110	D	GLV114
1 1/2"	15	61	31	27	160	E	GLV112
2"	15	76	38	33,5	340	E	GLV200
2 1/2"	15	90	44	40,5	427	E	GIV075
3"	15	108	51	48	768	E	GLV300
4"	15	131	63	58	972	E	GLV400
6"	12	194,5	90	90	3480	D	GLV600
8"	12	257	115,5	169,5	8850	D	GLV800



HLV

45° elbow with solvent weld sockets

d	PN	E	L	Z	g	Class	Code
1/2"	15	27	16,5	5	13	E	HLV012
3/4"	15	33	19,5	5,5	20	E	HLV034
1"	15	41	22,5	7	45	E	HLV100
1"1/4	15	50	26	10,5	85	D	HLV114
1"1/2	15	61	31	11,5	155	E	HLV112
2"	15	76	38	14	291	E	HLV200
2"1/2	15	90	44	17	315	E	HIV075
3"	15	107,5	51	21,5	565	E	HLV300
4"	15	131	61	26	740	E	HLV400

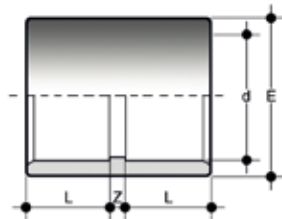

MLV

Solvent weld double socket

d	PN	E	L	Z	g	Class	Code
1/2"	15	27	16,5	2	13	E	MLV012
3/4"	15	33	19,5	2	15	E	MLV034
1"	15	41	22,5	2	36	E	MLV100
1"1/4	15	50	26	3	58	D	MLV114
1"1/2	15	61	31	3	118	E	MLV112
2"	15	76	38	3	206	E	MLV200
2"1/2	15	90	44	4	250	E	MIV075
3"	15	108	50,5	5,5	420	E	MLV300
4"	15	131	63	5	680	E	MLV400
6"	12	194,5	90	10	1800	D	MLV600
8"	12	257	115,5	12	4950	D	MLV800

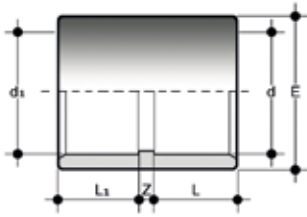

MILV

mm/inch double socket union, one socket for solvent welding to metric pipes and one for solvent welding to imperial (inches) pipes

$d \times d_1$	PN	E	L	L_1	Z	g	Class	Code
20 x 1/2"	15	27	16	16,5	2,5	12	E	MILV020012
25 x 3/4"	15	33	19	19,5	2,5	22	E	MILV025034
32 x 1"	15	41	22	22,5	2,5	44	E	MILV032100
40 x 1 1/4"	15	50	26	27	2,0	65	E	MILV040114
50 x 1 1/2"	15	61	31	30	4,0	125	E	MILV050112
63 x 2"	15	76	38	36	5,0	210	E	MILV063200
75 x 2 1/2"	15	90	44	44	4,0	250	E	MIV075
90 x 3"	15	108	51	50,5	5,5	438	E	MILV090300
110 x 4"	15	131	61	63	4,0	852	E	MILV110400

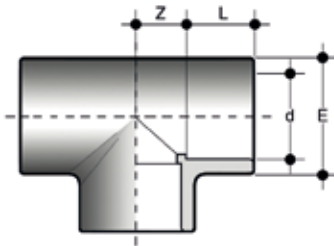

TLV

90° Tee with solvent weld sockets

d	PN	E	L	Z	g	Class	Code
1/2"	15	27	16,5	10,5	26	E	TLV012
3/4"	15	33	19,5	13,5	30	E	TLV034
1"	15	41	22,5	17	55	E	TLV100
1 1/4"	15	50	26	22	90	D	TLV114
1 1/2"	15	61	31	27	257	E	TLV112
2"	15	76	38	33,5	495	E	TLV200
2 1/2"	15	90	44	40,5	560	E	TIV075
3"	15	108	51	48	970	E	TLV300
4"	15	131	63	59	1260	E	TLV400
6"	12	194,5	90	90	4400	D	TLV600
8"	12	257	115,5	116	10500	D	TLV800

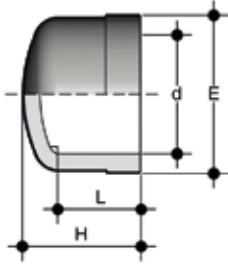

CLV

End cap with solvent weld socket

d	PN	E	L	Z	g	Class	Code
1/2"	15	27	16,5	2	13	E	CLV012
3/4"	15	33	19,5	2	15	E	CLV034
1"	15	41	22,5	2	36	E	CLV100
1"1/4	12	50	26	3	58	E	CLV114
1"1/2	15	61	31	3	118	E	CLV112
2"	15	76	38	3	206	E	CLV200
2"1/2	12	90	44	4	250	E	CIV075
3"	15	108	50,5	5,5	420	E	CLV300
4"	15	131	63	5	680	E	CLV400

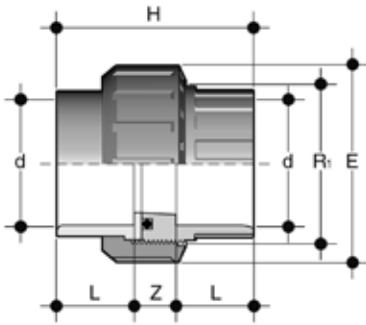

BLV

Union with solvent weld sockets, O-Ring in EPDM

d	PN	R ₁	E	H	L	Z	g	Class	Code
1/2"	15	1"	40.5	45	16	13	39	E	BLV012E
3/4"	15	1 1/4"	50	51	19	13	65	E	BLV034E
1"	15	1 1/2"	57.5	57	22	13	94	E	BLV100E
1 1/4"	15	2"	71.5	67	26	15	150	E	BLV114E
1 1/2"	15	2 1/4"	79	79	31	17	190	E	BLV112E
2"	15	2 3/4"	98	98	38	21	400	E	BLV200E

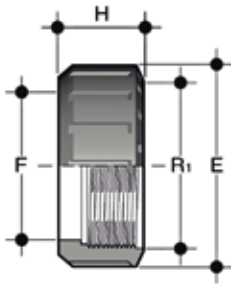

EFV

Union nut with BSP thread for union types BIV, BIFV, BFV, BLV, BIRV, BIFOV, BIROV, BIFXV, BIRXV

R ₁	d BLV	PN	E	F	H	g	Code
1/2"	-	16	27	17	24	8	EFV012
3/4"	16	16	33	22	21	9	EFV034
1"	20	16	41	28	22	13	EFV100
1 1/4"	25	16	50	36	25	22	EFV114
1 1/2"	32	16	58	42	27	30	EFV112
2"	40	16	72	53	30	50	EFV200
2 1/4"	50	16	79	59	34	68	EFV214
2 1/2"	-	16	90	68	36	95	EFV212
2 3/4"	63	16	98	74	38	120	EFV234
3 1/2"	75	10	120	93	45	198	EFV312
4"	90	10	135	106	52	278	EFV400
5"	110	10	163	129	60	448	EFV500

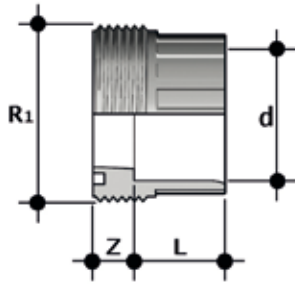

F/BLV

Union bush for solvent welding, series BS for union types BIV, BIFV, BFV, BLV, BIRV, BIFOV, BIROV, BIFXV, BIRXV

d	R ₁	PN	L	Z	g	Code
1/2"	1"	15	16	10	12,5	FBLV012
3/4"	1 1/4"	15	19	10	22,5	FBLV034
1"	1 1/2"	15	22	10	30	FBLV100
1 1/4"	2"	15	26	12	52	FBLV114
1 1/2"	2 1/2"	15	31	14	69,5	FBLV112
2"	2 3/4"	15	38	19	133,5	FBLV200

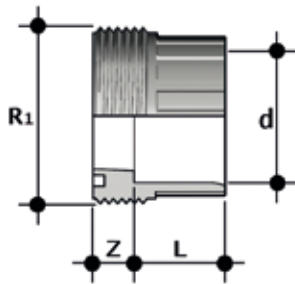

F/BIV

Union bush for solvent welding, metric series for union types BIV, BIFV, BFV, BLV, BIRV, BIFOV, BIROV, BIFXV, BIRXV

d	R ₁	PN	L	Z	g	Code
16	3/4"	16	14	10	9	FBIV016
20	1"	16	16	10	13	FBIV020
25	1 1/4"	16	19	10	25	FBIV025
32	1 1/2"	16	22	10	31	FBIV032
40	2"	16	26	12	58	FBIV040
50	2 1/4"	16	31	14	63	FBIV050
63	2 3/4"	16	38	19	119	FBIV063
75	3 1/2"	10	44	18	230	FBIV075
90	4"	10	51	18	290	FBIV090
110	5"	10	61	18	500	FBIV110

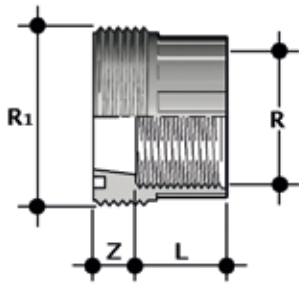

F/BFV

Union bush with BSP threaded female end for union types BIV, BIFV, BFV, BLV, BIRV, BIFOV, BIROV, BIFXV, BIRXV

R	R ₁	PN	L ₁	Z	g	Code
3/8"	3/4"	16	11,4	12,6	8	FBFV038
1/2"	1"	16	15	11	13	FBFV012
3/4"	1 1/4"	16	16,3	12,7	22	FBFV034
1"	1 1/2"	16	19,1	12,9	32	FBFV100
1 1/4"	2"	16	21,4	16,6	57	FBFV114
1 1/2"	2 1/4"	16	21,4	16,5	64	FBFV112
2"	2 3/4"	16	25,7	20,5	122	FBFV200

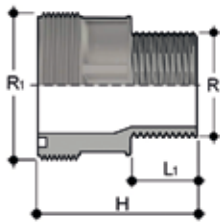

F/BRV

Union bush with BSP threaded male end for union types BIV, BIFV, BFV, BLV, BIRV, BIFOV, BIROV, BIFXV, BIRXV

R	R ₁	PN	L ₁	g	Code
1 1/2"	2 1/4"	16	22,5	100	FBRV112214
2"	2 1/4"	16	27	120	FBRV200214
2"	2 3/4"	16	27	175	FBRV200234

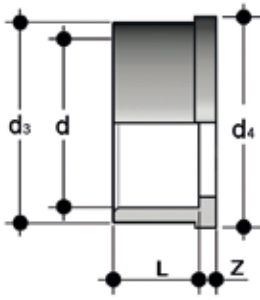

Q/BLV

Union end for solvent welding, BS series for union types BIV, BIFV, BFV, BLV, BIRV, BIFOV, BIROV, BIFXV, BIRXV

d	PN	d ₃	d ₄	L	Z	g	Code
1/2"	15	27,5	30,1	16	3	8	QBLV012
3/4"	15	36	38,8	19	3	13	QBLV034
1"	15	41,5	44,7	22	3	19	QBLV100
1 1/4"	15	53	56,5	26	3	32	QBLV114
1 1/2"	15	59	62,6	31	3	46	QBLV112
2"	15	74	78,4	38	3	86	QBLV200

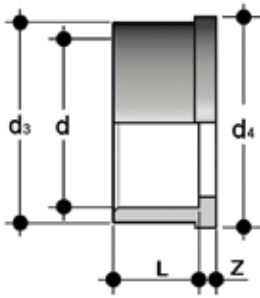

Q/BAV

Union end for solvent welding, ASTM series for union types BIV, BIFV, BFV, BLV, BIRV, BIFOV, BIROV, BIFXV, BIRXV

d	PN	d ₃	d ₄	L	Z	g	Code
1/2"	16	27,5	30,1	22,7	3,5	15,5	QBAV012
3/4"	16	36	38,8	25,9	3,7	22,5	QBAV034
1"	16	41,5	44,7	29,2	3	32,5	QBAV100
1 1/4"	16	53	56,5	32	5	57	QBAV114
1 1/2"	16	59	62,6	35	5	78	QBAV112
2"	16	74	78,4	38,5	5,5	130	QBAV200

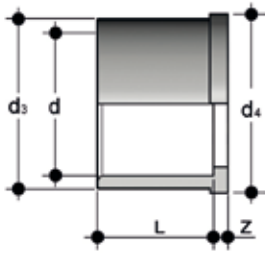

Q/BJV

Union end for solvent welding, JIS series for union types BIV, BIFV, BFV, BLV, BIRV, BIFOV, BIROV, BIFXV, BIRXV

d	PN	d ₃	d ₄	L	Z	g	Code
1/2"	16	27,5	30,1	30	3	16	QBJV012
3/4"	16	36	38,8	35	3,5	21	QBJV034
1"	16	41,5	44,7	40	3	40	QBJV100
1 1/4"	16	53	56,5	44	3	68	QBJV114
1 1/2"	16	59	62,6	55	4,5	105	QBJV112
2"	16	74	78,4	62,9	5,5	175	QBJV200

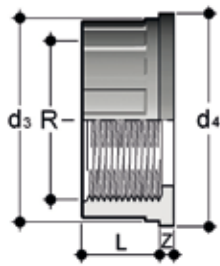

Q/BFV

Union end with BSP female thread for union types BIV, BIFV, BFV, BLV, BIRV, BIFOV, BIROV, BIFXV, BIRXV

R	PN	d ₃	d ₄	L	Z	g	Code
3/8"	16	22	24	11,4	4,5	4,5	QBFV038
1/2"	16	27,5	30,1	15	5	8,5	QBFV012
3/4"	16	36	38,8	16,3	5	15,5	QBFV034
1"	16	41,5	44,7	19,1	5,5	21,0	QBFV100
1 1/4"	16	53	56,5	21,4	5,5	33,5	QBFV114
1 1/2"	16	59	62,6	21,4	5,5	40,0	QBFV112
2"	16	74	78,4	25,7	5,5	72,0	QBFV200

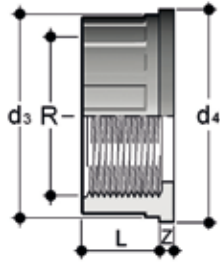

Q/BNV

Union end with NPT female thread for union types BIV, BIFV, BFV, BLV, BIRV, BIFOV, BIROV, BIFXV, BIRXV

R	PN	d_3	d_4	L	Z	g	Code
3/8"	16	22	24	12,7	6,3	10	QBNV038
1/2"	16	27,5	30,1	17,8	5,2	15	QBNV012
3/4"	16	36	38,8	18	5,2	20	QBNV034
1"	16	41,5	44,7	22,6	5,7	30	QBNV100
1 1/4"	16	53	56,5	25,1	7,3	55	QBNV114
1 1/2"	16	59	62,6	24,7	7	70	QBNV112
2"	16	74	78,4	29,6	7,8	115	QBNV200

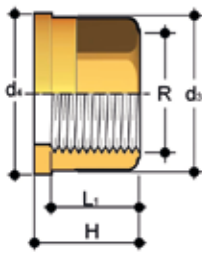

Q/BFO

Union end in brass with female BSP thread for union types BIV, BIFV, BFV, BLV, BIRV, BIFOV, BIROV, BIFXV, BIRXV

R	d_3	d_4	H	L_1	g	Code
3/8"	22	24	21,5	13,5	38	QBFO038
1/2"	27,5	30,1	22,5	16,5	60	QBFO012
3/4"	36	38,8	25,5	18,5	116	QBFO034
1"	41,5	44,7	27,5	19,5	144	QBFO100
1 1/4"	53	56,5	30,5	21,5	260	QBFO114
1 1/2"	59	62,6	33,5	23	325	QBFO112
2"	74	78,4	38,5	27	578	QBFO200

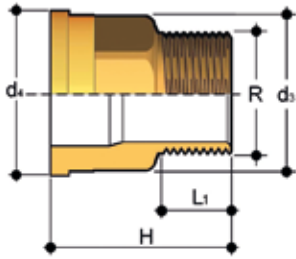

Q/BRO

Union end in brass with male BSP thread for union types BIV, BIFV, BFV, BLV, BIRV, BIFOV, BIROV, BIFXV, BIRXV

R	d ₁	d ₂	H	L ₁	g	Code
3/8"	22	24	34,5	10,5	64	QBRO038
1/2"	27,5	30,1	39	13,5	105	QBRO012
3/4"	36	38,8	43,5	15	184	QBRO034
1"	41,5	44,7	48	17,5	251	QBRO100
1 1/4"	53	56,5	53	19,5	437	QBRO114
1 1/2"	59	62,6	56	19,5	545	QBRO112
2"	74	78,4	65,5	24	937	QBRO200

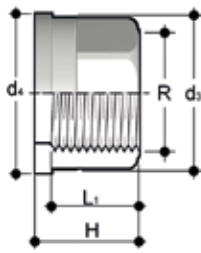

Q/BFX

Union end in A316L stainless steel with female BSP thread for union types BIV, BIFV, BFV, BLV, BIRV, BIFOV, BIROV, BIFXV, BIRXV

R	d ₁	d ₂	H	L ₁	g	Code
3/8"	22	24	21,5	13,5	34	QBFX038
1/2"	27,5	30,1	22,5	16,5	54	QBFX012
3/4"	36	38,8	25,5	18,5	104	QBFX034
1"	41,5	44,7	27,5	19,5	130	QBFX100
1 1/4"	53	56,5	30,5	21,5	234	QBFX114
1 1/2"	59	62,6	33,5	23	293	QBFX112
2"	74	78,4	38,5	27	520	QBFX200

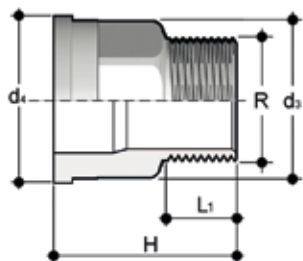

Q/BRX

Union end in A316L stainless steel with male BSP thread for union types BIV, BIFV, BFV, BLV, BIRV, BIFOV, BIROV, BIFXV, BIRXV

R	d ₂	d ₃	H	L ₁	g	Code
3/8"	22	24	34,5	10,5	58	QBRX038
1/2"	27,5	30,1	39	13,5	95	QBRX012
3/4"	36	38,8	43,5	15	166	QBRX034
1"	41,5	44,7	48	17,5	226	QBRX100
1 1/4"	53	56,5	53	19,5	393	QBRX114
1 1/2"	59	62,6	56	19,5	491	QBRX112
2"	74	78,4	65,5	24	843	QBRX200

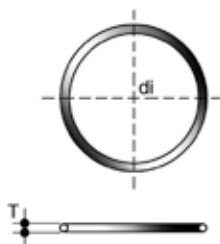

O-RING

O-ring for union types BIV, BIFV, BFV, BLV, BIRV, BIFOV, BIROV, BIFXV, BIRXV

Union D	C	di	T	EPDM code	FKM code
16	3062	15,54	2,62	OR3062E	OR3062F
20	4081	20,22	3,53	OR4081E	OR4081F
25	4112	28,17	3,53	OR4112E	OR4112F
32	4131	32,93	3,53	OR4131E	OR4131F
40	6162	40,65	5,34	OR6162E	OR6162F
50	6187	47	5,34	OR6187E	OR6187F
63	6237	59,69	5,34	OR6237E	OR6237F
75	6300	75,57	5,34	OR6300E	OR6300F
90	6362	91,45	5,34	OR6362E	OR6362F
110	6450	113,67	5,34	OR6450E	OR6450F

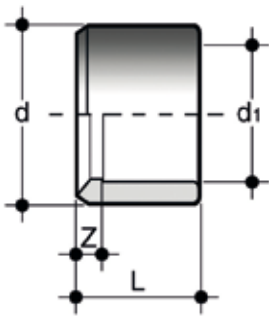

Fig. A

DLV

Reducing bush with solvent weld spigot (d) and solvent weld socket (d1 reduced) (fig. A)

d x d ₁	PN	L	Z	g	Code
1/2" x 3/8"	15	16,5	2	3	DLV012038
3/4" x 1/2"	15	19,5	3	5,5	DLV034012
1" x 1/2"	15	22,5	6,5	18	DLV100012
1" x 3/4"	15	22,5	3	10	DLV100034
1 1/4" x 1"	15	27	4	19	DLV114100
1 1/2" x 1"	15	30	7,5	42	DLV112100
1 1/2" x 1 1/4"	15	31	4	20	DLV112114
2 1/2" x 2"	15	43,5	7,5	100	DLV212200
3" x 2 1/2"	15	50,5	7	125	DLV300212
4" x 3"	15	63	12	331	DLV400300

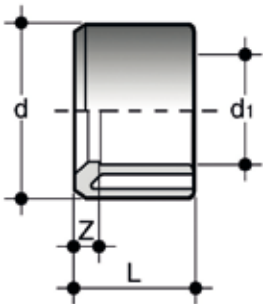
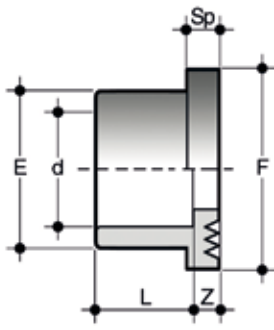

Fig. B

DLV

Reducing bush with solvent weld spigot (d) and solvent weld socket (d1 reduced) (fig. B)

d x d ₁	PN	L	Z	g	Code
1 1/2" x 3/4"	15	30	10	40	DLV112034
2" x 1"	15	36	7	50	DLV200100
2" x 1 1/2"	15	38	7	50	DLV200112
3" x 1 1/2"	15	50,5	20,5	200	DLV300112
3" x 2"	15	51	13	167	DLV300200
4" x 2"	15	63	27	370	DLV400200
6" x 4"	12	90	27	972	DLV600400
8" x 6"	12	115,5	26,5	1400	DLV800600



QLV

Serrated face stub with solvent weld socket, for use with stubs QLV and flat gaskets QHV/X and QHV/Y (QHV/Y only when coupling to ISO/DIN "ODV and ODB" flanges)

d	PN	E	F	L	Sp	Z	g	Class	Code
2"	15	76	90	38	9	3	110	E	QLV200
2 1/2"	15	90	106	44	10	3	165	E	QPV075
3"	15	108	125	51	11	5	270	E	QLV300
4"	15	131	158	61	12	5	445	E	QLV400
6"	12	188	216	86	16	5	1250	D	QLV600
8"	12	250	270	115	20	6,5	2150	D	QLV800

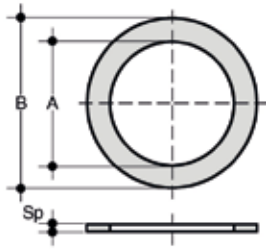

QHV/X

Flat gasket in EPDM and FKM for flanges according to DIN 2501, EN 1092

d	DN	A	B	Sp	EPDM code	FKM code
16	10	16	27	2	QHVX016E	QHVX016F
20 - 1/2"	15	20	32	2	QHVX020E	QHVX020F
25 - 3/4"	20	24	38,5	2	QHVX025E	QHVX025F
32 - 1"	25	32	48	2	QHVX032E	QHVX032F
40 - 1" 1/4	32	40	59	2	QHVX040E	QHVX040F
50 - 1" 1/2	40	50	71	2	QHVX050E	QHVX050F
63 - 2"	50	63	88	2	QHVX063E	QHVX063F
75 - 2" 1/2	65	75	104	2	QHVX075E	QHVX075F
90 - 3"	80	90	123	2	QHVX090E	QHVX090F
110 - 4"	100	110	148	3	QHVX110E	QHVX110F
125	125	125	166	3	QHVX125E	QHVX125F
140	125	140	186	3	QHVX140E	QHVX140F
160 - 6"	150	160	211	3	QHVX160E	QHVX160F
200	200	200	252	4	QHVX200E	-
225 - 8"	200	225	270	4	QHVX225E	-
250	250	250	305	4	QHVX250E	-

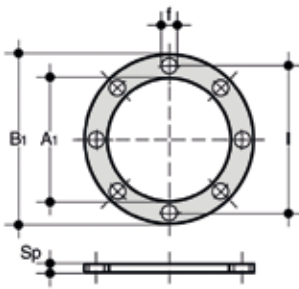

QHV/Y

Flat gasket in EPDM for flanges according to DIN 2501, EN 1092, self-centring for flanges drilled PN 10/16 up to DN 150 and PN 10 from DN 200

d	DN	A ₁	B ₁	F	I	U	Sp	Code
20 - 1/2"	15	17	95	14	65	4	2	QHVV020E
25 - 3/4"	20	22	107	14	76,3	4	2	QHVV025E
32 - 1"	25	28	117	14	86,5	4	2	QHVV032E
40 - 1" 1/4	32	36	142,5	18	101	4	2	QHVV040E
50 - 1" 1/2	40	45	153,3	18	111	4	2	QHVV050E
63 - 2"	50	57	168	18	125,5	4	2	QHVV063E
75 - 2" 1/2	65	71	187,5	18	145,5	4	3	QHVV075E
90 - 3"	80	84	203	18	160	8	3	QHVV090E
110 - 4"	100	102	223	18	181	8	3	QHVV110E
125	125	132	250	18	210	8	3	QHVV125EDN125
140	125	132	250	18	210	8	3	QHVV140E
160 - 6"	150	152	288.5	22	241,5	8	4	QHVV160E
200	200	192	340	22	295	8	4	QHVV200E
225 - 8"	200	215	340	22	295	8	4	QHVV225E
250	250	238	395	22	350	12	4	QHVV250E
280	250	265	395	22	350	12	4	QHVV280E
315	300	290	462	22	400	12	4	QHVV315E
355	350	337	500	22	460	16	2	QHVV355E
400	400	384	555	22	515	16	2	QHVV400E

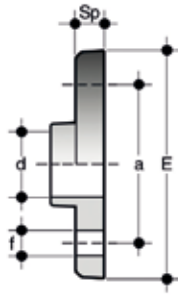

FLV

Flange to BS 10, table E, with solvent weld socket (for gasket sizes, see QHV/X)

d	PN	a	E	f	L	Sp	U	Z	g	Class	Code
1/2"	15	67	95	14	16,5	11	4	5	100	E	FLV012
3/4"	15	73	105	14	19,5	12	4	5	140	E	FLV034
1"	15	82,5	115	14	22,5	14	4	5	200	E	FLV100
1 1/4"	15	87,5	125	14	27	15	4	5	265	E	FLV114
1 1/2"	15	98,5	140	14	31	16	4	5	350	E	FLV112
2"	15	115	165	18	38	18	4	5	500	E	FLV200
3"	15	146	200	18	51	20,5	4	5,5	860	E	FLV300
4"	15	178	220	18	63	22,5	8	5,5	1100	E	FLV400

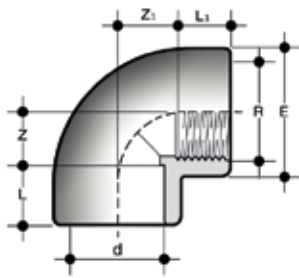

GLFV

90° elbow with solvent weld socket and BSP threaded female end R

d x R	PN	E	L	L ₁	Z	Z ₁	g	Class	Code
1/2" x 1/2"	15	27	16,5	15	10,5	12	13	E	GLFV012
3/4" x 3/4"	15	33	19,5	16,3	13,5	16,7	25	E	GLFV034
1" x 1"	15	41	22,5	19,1	17	20,4	55	E	GLFV100
1 1/2" x 1 1/2"	15	61	31	21,4	27	36,6	170	E	GLFV112
2" x 2"	15	76	38	25,7	33,5	45,8	340	E	GLFV200
2 1/2" x 2 1/2"	12	90	44	30,2	40,5	54,3	420	E	GIFV075212
3" x 3"	12	108	51	33,3	48	65,7	750	D	GLFV300
4" x 4"	12	131	63	39,3	58	81,7	1050	D	GLFV400

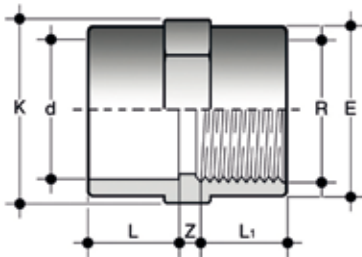

MLFV

Double socket with solvent weld socket d and BSP threaded female end R

d x R	PN	E	K	L	L ₁	Z	g	Class	Code
1/2" x 1/2"	15	27	24	16	15	4	15	E	MLFV012
3/4" x 3/4"	15	33	29	19,5	16,3	5,2	25	E	MLFV034
1" x 1"	15	41	35	22,5	19,1	4,5	45	E	MLFV100
1 1/4" x 1 1/4"	15	50	43	27	21,4	4	65	E	MLFV114
1 1/2" x 1 1/2"	15	61	50	30	21,4	8	100	E	MLFV112
2" x 2"	15	76	61	36	25,7	9	160	E	MLFV200
2 1/2" x 2 1/2"	12	90	76	44	30,2	17,8	260	E	DIFV090075212
3" x 3"	12	108	108	51	33,3	22,7	449	D	MLFV300

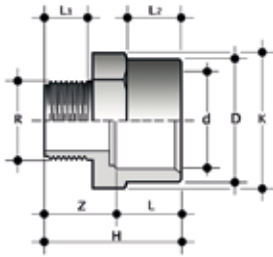

ILFV

Female/male adaptor with solvent weld socket d and BSP threaded male end R

d x R	PN	H	K	L	L ₁	Z	g	Class	Code
1/2" x 1/2"	15	37,5	30	16,5	15	21	20	E	ILFV012
3/4" x 3/4"	15	42	36	19,5	16,3	22,5	22	E	ILFV034
1" x 1"	15	47,5	46	22,5	19,1	25	25	E	ILFV100
1 1/4" x 1 1/4"	15	56,5	55	27	21,4	29,5	65	E	ILFV114
1 1/2" x 1 1/2"	15	62	65	31	21,4	31	98	E	ILFV112
2" x 2"	15	73	80	38	25,7	35	160	E	ILFV200

Key Abbreviations

ABS	Acrylonitrile butadiene styrene
b	Bolts
c	O-ring code
d	Nominal external diameter of the pipe in mm
DA	Double acting
DN	Nominal internal diameter of the pipe in mm
EPDM	Ethylene-Propylene-Diene-Monomer
FKM (FPM)	Fluoroelastomer
g	Weight in grams
HIPVC	PVC high impact
K	Lid key
Kg	Weight in kilograms
L	Length in meters
MRS	minimum guaranteed breaking strength of the material at 20°C - water - for 50 years of service
n	Number of flange holes
NBR	Nitrile butadiene rubber
OP	Working pressure
P	Hose adaptor
PA	Polyamide
PA-GR	Fibreglass reinforced polyamide
PBT	Polybutylene terephthalate
PE	Polyethylene
PN	Nominal pressure in bar (max.operating pressure at 20°C water)
POM	Polyoxymethylene
PP-GR	Fibreglass reinforced polypropylene
PP-H	Polypropylene homopolymer

PPS	Polifenilensulfide
PPSU	Polifenilsulfone
PTFE	Politetrafluoroetilene
PVC-C	Chlorinated polyvinyl chloride
PVC-U	Unplasticized polyvinylchloride
PVDF	Polyvinylidene difluoride
R	Nominal thread size in inches
s	Pipe thickness in mm
S	Thickness series = $(SDR - 1)/2$
SA	Single acting
SDR	Standard dimension ratio = d/s
Sp	Flange thickness on flanged valves
U	Number of holes for flanged version



FIP Formatura Iniezione Polimeri

Loc. Pian di Parata, 16015 Casella Genova Italy

Tel. +39 0109621.1 - Fax +39 010 9621.209

info.fip@alixis.com

www.fipnet.com

UNI EN
ISO 9001
QUALITÀ

UNI EN
ISO 14001
GESTIONE
AMBIENTALE

